



INSTRUCTIONS AND MAINTENANCE MANUAL
2-POST HYDRAULIC LIFT JACK,
WITH TOP BAR

Art. No. 1918500050

Art. No. 0900700143

PACKING, TRANSPORT AND STORAGE	4
PACKING.....	4
LIFTING AND HANDLING.....	4
STORAGE.....	4
CRATE STACKING.....	5
OPENING THE CRATES.....	5
DISPOSAL OF CRATES.....	5
INTRODUCTION WARNING.....	5
LIFT SAFETY.....	5
THE SAFETY OF LIFTED VEHICLES.....	5
CONSERVING THE MANUAL.....	5
LAWS.....	6
CHAPTER 1 DESCRIPTION OF THE MACHINE	7
1.1 FIXED STRUCTURE (FIG.4).....	8
1.2 MOVING UNITS (SEE FIG.4).....	8
1.3 LIFT UNIT (SEE FIG.4).....	8
1.4 HYDRAULIC POWER UNIT (FIG.5).....	9
1.5 CONTROL BOX (FIG.6).....	9
1.6 SAFETY DEVICE.....	9
CHAPTER 2 TECHNICAL SPECIFICATIONS	10
2.1 ELECTRIC MOTOR.....	12
2.2 HYDRAULIC UNIT PUMP.....	12
2.3 OIL.....	12
2.4 HYDRAULIC OIL DIAGRAM.....	12
2.5 VEHICLE WEIGHT AND SIZE.....	14
2.6 MAXIMUM DIMENSIONS OF VEHICLES TO BE LIFTED.....	15
CHAPTER 3 SAFETY	16
3.1 GENERAL PRECAUTIONS.....	17
3.2 RISKS OF ELECTRIC SHOCK:.....	17
3.3 RISKS AND PROTECTION DEVICES.....	17
3.4 LONGITUDINAL AND LATERAL MOVEMENT.....	17
3.5 RISKS WHILE THE VEHICLE IS BEING RAISED.....	18
3.6 RISKS OF PERSONS.....	20
3.6.1 RISK OF CRUSHING (OPERATOR)	20
3.6.2 RISK OF CRUSHING (PERSONNEL)	20
3.6.3 RISK OF IMPACT	20
3.6.4 RISK DUE TO VEHICLE MOVEMENT	20
3.6.5 RISK OF VEHICLE FALLING FROM LIFT	21
3.6.6 SLIPPING	21
3.6.7 RISK OF ELECTRIC SHOCK	22
3.6.8 RISK OF COMPONENT FAILURE DURING OPERATION	22
3.6.9 RISK RELATED TO IMPROPER USE	22
3.7 SAFETY INSTRUCTIONS FOR SERVICING	22

CHAPTER 4 INSTALLATION	23
4.1 INSTALLATION REQUISITE CHECKLIST	23
4.2 LIGHTENING.....	24
4.3 FLOOR	24
4.4 ASSEMBLING	25
4.4.1 PUT COLUMN	25
4.4.2 HYDRAULIC PLANT	26
4.4.3 ELECTRIC PLANT CONNECTION.....	26
4.4.4 ARM ASSEMBLING	28
4.4.5 INSTALL THE COVER PLATE.....	29
4.5 TESTING AND CHECKS TO PERFORM BEFORE START-UP	30
4.5.1 MECHANIAL TESTS	30
4.5.2 ELECTRIC TESTS.....	30
4.5.3 OPERATING OF THE FOLLOWING DEVICES.....	30
4.5.4 HYDRAULIC OIL TEST	30
4.5.5 ROTATION DIRECTION TEST	30
4.6 SET UP	31
4.6.1 VACUUM TEST (without vehicles loaded).....	31
4.6.2 LOAD TESTS.....	31
CHAPTER 5 OPERATIONS AND USE	32
CONMANDS.....	32
5.1.1 MAIN SWITCH (IG).....	32
5.1.2 UP PUSH BUTTON.....	32
5.1.3 DOWN PUSH BUTTON	32
5.1.4 LOCK PUSH BUTTON.....	32
5.2 OPERATING SEQUENCE.....	32
5.2.1 LIFTING	32
5.2.2 PARKING.....	33
5.2.3 LOWERING.....	33
CHAPTER 6. MAINTENANCE	34
PRECAUTIONS.....	34
6.2 PERIODIC MAINTENANCE.....	35
6.2.1 OPERATION FREQUENCY	35
6.2.2 EVERY MONTH.....	35
6.2.3 EVERY 3-MONTH... ..	35
6.2.4 EVERY 6-MONTH... ..	36
6.2.5 EVERY 12-MONTH... ..	36
6.3 PERIODIC LUBRIFICATION CHART	37
CHAPTER 7 TROUBLESHOOTING	38
7.1 TROUBLESHOOTING GUIDE.....	38
7.2 POSSIBLE PROBLEMS AND SOLUTIONS.....	38
APPENDIX A-SPECIAL NOTES	39
APPENDIX B SPARE PARTS	39

PACKING, TRANSPORT AND STORAGE

ALL PACKING, LIFTING, HANDLING, TRANSPORT AND UNPACKING OPERATIONS ARE TO BE PERFORMED EXCLUSIVELY BY EXPERT PERSONNEL WITH KNOWLEDGE OF THE LIFT AND THE CONTENTS OF THIS MANUAL

PACKING

The lift is shipped disassembled into following parts: Weight (kg)

Command post, complete with carriage, chain, hydraulic cylinder and control panel 320kg

Service side post, complete with carriage, chain and hydraulic cylinder 310kg

Crossbeam 30kg

Long arms complete with extension and plate 35kg

Short arms complete with extension and plate 30kg

Power unit complete with motor and support 30kg

Accessory package, nuts and bolts 27kg

Foot guards 3kg

Box containing 4 arm-blocking kits

The lift is dispatched in an iron crate (Fig.1), weighing approx.850kg.

LIFTING AND HANDLING

The crates may be lifted and moved with a lift truck (Fig.1).If either of the latter two are used , crates must be harnessed with at least 2 slings.

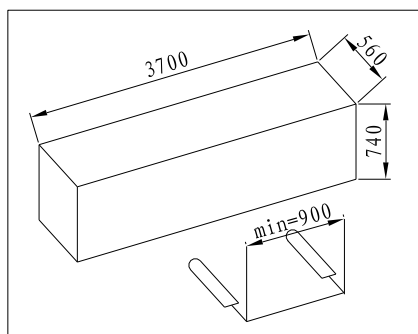

Fig.1

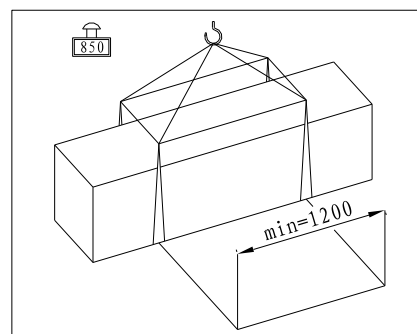

Fig.2

The equipment chosen must be suitable for safe lifting and moving, bearing in mind the dimensions and weight.

STORAGE

Packed machinery must always be kept in a covered, protected place, at a temperature between -10° And +40° And must not be exposed to direct sunlight.

CRATE STACKING

The type of packing allows the possibility of stacking up to 3 crates.

Up to 3 crates may be stacked one upon the other on lorries or in containers if property positioned and provided they are restrained to prevent falling.

OPENING THE CRATES

When the crates arrive, check that the machine has not been damaged during transport and that all parts listed are present. The crates must be opened using all possible precautionary measure to avoid damaging the machine or its parts. Make sure that parts do not fall from the crate during opening.

DISPOSAL OF CRATES

The crates may be reused or recycled.

INTRODUCTION WARNING

This manual has been prepared for workshop personnel expert in the use of the lift (operator) and technicians responsible for routine maintenance (maintenance fitter): read the manual before carrying out any operation with the lift and /or the packing. This manual contains important information regarding:

THE PERSONAL SAFETY OF operators and maintenance workers

LIFT SATETY

THE SAFETY OF LIFTED VEHICLES

4000kg

Express the rated load is 4000kg, don't allow the lift load weigh excess 4000kg.



This symbol express attention should be taken for electrical hazards

CONSERVING THE MANUAL

The manual is an integral part of the lift, which it should always accompany even if the unit is sold .The manual must be kept in the vicinity of the lift in an easily accessible place so that the operator and maintenance staff must be able to locate and consult the manual quickly at any time.

ATTENTIVE AND REPEATED READING OF CHAPTER 3, WHICH CONTAINS IMPORTANT INFORMATION AND SAFETY WARNINGS, IS PARTICULARLY RECOMMENDED.

Lift rack has been designed and built in compliance with the following:

LAWS

The lifting, transport, unpacking, assembling, installation, starting up, initial adjustment and testing, EXTRAORDINARY maintenance, repair, overhauls, transport and dismantling of the lift must be performed by specialist personnel from the LICENSED DEALER or an SERVICE CENTRE authorized by the manufacturer (see authorized dealer on frontispiece).

The manufacturer declines all responsibility for injury to persons or damage to vehicles or objects when any of the above mentioned operations have been performed by unauthorized personnel or when the rack has been subject to abuse.

This manual indicates only the operative and safety aspects that may prove useful to the operator and maintenance works better understanding the structure and operation of the lift and for best use of the lift.

In order to understand the terminology used in this manual, the operator must have specific experience in workshop, service, maintenance and repair activities, the ability to interpret correctly the drawings and descriptions contained in the manual and be acquainted with the general and specific safety rules relevant to the country in which the machine has been installed.

The same applies to the maintenance fitter, who must also possess specific and specialized knowledge (mechanical, engineering) needed to perform the operations described in the manual in complete safety.

The words “operator” and “maintenance fitter” used in this manual are construed as follows:

OPERATOR: person authorized to use the lift.

WORKING CONDITIONS:

- 1、 Regarding ambient temperature shall be 5-40°C.
- 2、 Regarding humidity shall be 30-95%.
- 3、 Regarding transportation and storage temperature shall be between 25-55°C, and short period no exceeding 24 hours at up to 70°C.
- 4、 Regarding installation altitude max 1000m.

MAINTENANCE FITTER: person authorized for routine maintenance of the lift.

The end user can only use the machine in correct way as defined in instruction.

Loose clothes shall not be used protection cap shall also be used for long hair person, etc.

The end user should provide the MSDS (Material Safety Data Sheet) at easy accessible place when providing lubrication.

CHAPTER 1 DESCRIPTION OF THE MACHINE

The 2-post electro-hydraulic lift is a fixed installation. This means that it is anchored to the ground and built for lifting and positioning automobiles and vans at a certain height off the ground.

The lift consists of the following main parts:

1. Fixed structure (posts + upper beam);
2. Mobile units (carriages + arms);
3. Lift units (2 hydraulic cylinders + power unit);
4. Control box;
5. Safety devices;

Figures 3 and 4 illustrate the various parts of the lift and the work areas reserved for use by operators around the lift.

Command side: this side of the lift includes the area reserved for the operator to access the control box.

Service side: this is the opposite side of the command side.

Front side: the side with the short arms.

Rear side: the side with the long arms.

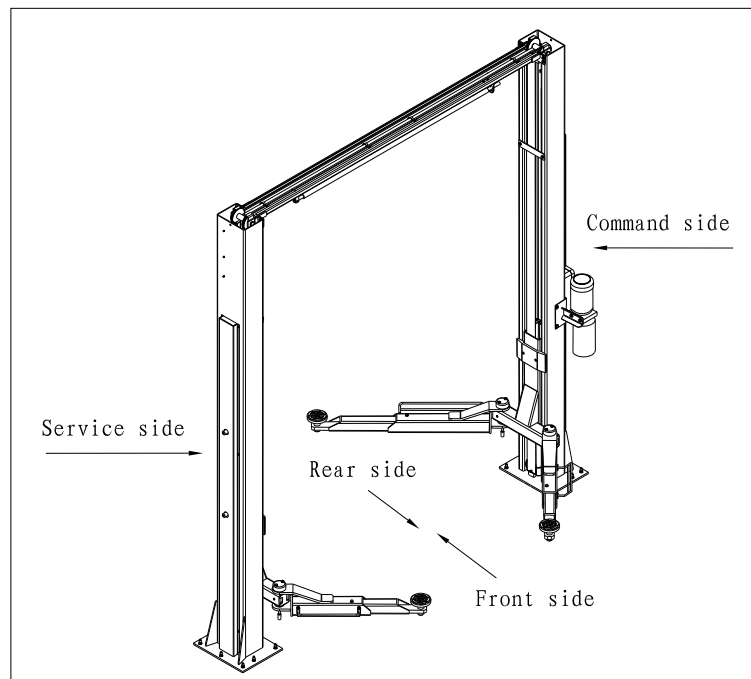

Fig.3

1.1 FIXED STRUCTURE (FIG.4)

This structure consists of:

1. 2 posts, (service 15 and command 3 side post) built with bent steel plate. The base is welded to a drilled plate to be anchored to the floor. The electric control box 4 and the hydraulic power unit 5 are attached to the command post. Inside each post are the moving parts to lift the vehicles. The control panel and the hydraulic unit are fixed to the command post.
2. An upper beam 1,17 built with bent steel plate, connecting the upper posts with bolts.

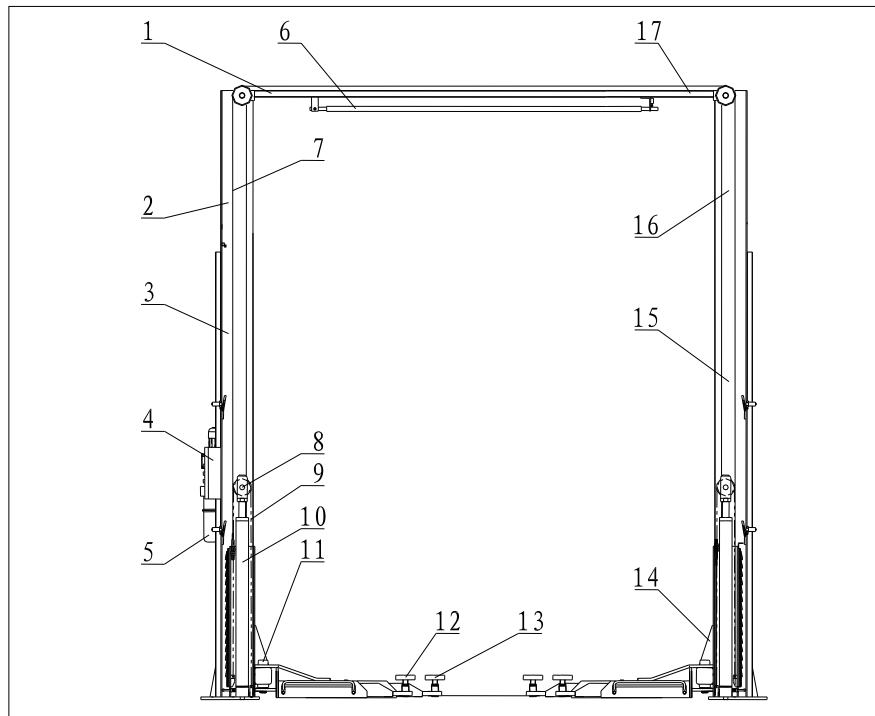

Fig.4

1.2 MOVING UNITS (SEE FIG.4)

Each unit consists of:

1. Both carriage (10 and 14) built with welded steel plate. It joints by chain 8 and the steel wire 7, and at the bottom to the lift arms by means of pins.
The carriage moves along the post, guided by plastic sliding pads, located inside the post itself.
2. Two telescopic arms, one long (13) and one short (12), built with tubular steel with a pad at each end that can be height adjusted to hold the car and on the opposite side the carriage connection hole.

1.3 LIFT UNIT (SEE FIG.4)

It consists of:

1. 2 hydraulic cylinders (10), the carriages run by chains, and the cable keep both of them in parallel.
2. 1 hydraulic unit (2), on the command side, to set the cylinders run.

1.4 HYDRAULIC POWER UNIT (FIG.5)

The hydraulic power unit consists of:

1. An electric motor
2. A geared hydraulic pump
3. Descent hand-valve equipped with a manual oil drain valve (see the use and maintenance chapter)
4. A maximum pressure valve
5. Oil tank
6. An oil delivery and return flexible pipe to the cylinders feeding circuit

Note: The oil delivery pipe may be under pressure

1.5 CONTROL BOX (FIG.6)

The panel that houses the electric control box contains the following:

- 1 Main switch
- 2 Rise push button
- 3 Down push button
- 4 Lock push button

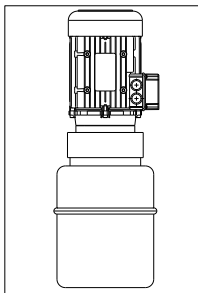

Fig.5 Hydraulic power unit

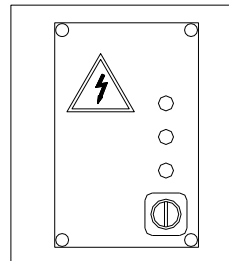

Fig.6 Control panel

1.6 SAFETY DEVICE

The safety devices include:

- 1 Mechanical safety device for carriage
- 2 Arms locking system
- 3 4 foot guards on the arms
- 4 A synchronous device to control the carriages movement.
- 5 2 post end limit switches
- 6 General electric safety devices
- 7 General hydraulic safety devices

These safety devices will be described in further detail in the following chapters

CHAPTER 2 TECHNICAL SPECIFICATIONS

CAPACITY	4000kg(39200N)
Car max lifting height	1900mm
Lift min stand height	110mm
Clearance between carriages	2760mm
Total width	3384mm
Long arm maximum length	1330mm
Long arm minimum length	845mm
Short arm maximum length	1100mm
Short arm minimum length	685mm
Rise time with three-phase motor	≤60sec
Rise time with single-phase motor	≤75sec
Descent time	20≤t≤60sec
Total lift weight	About 715 KG
Noise	≤70db (A) 1m
Operating temperature	5°C/40°C
Work environment	closed room
Relative humidity	90%
Sea level height	≤3500m

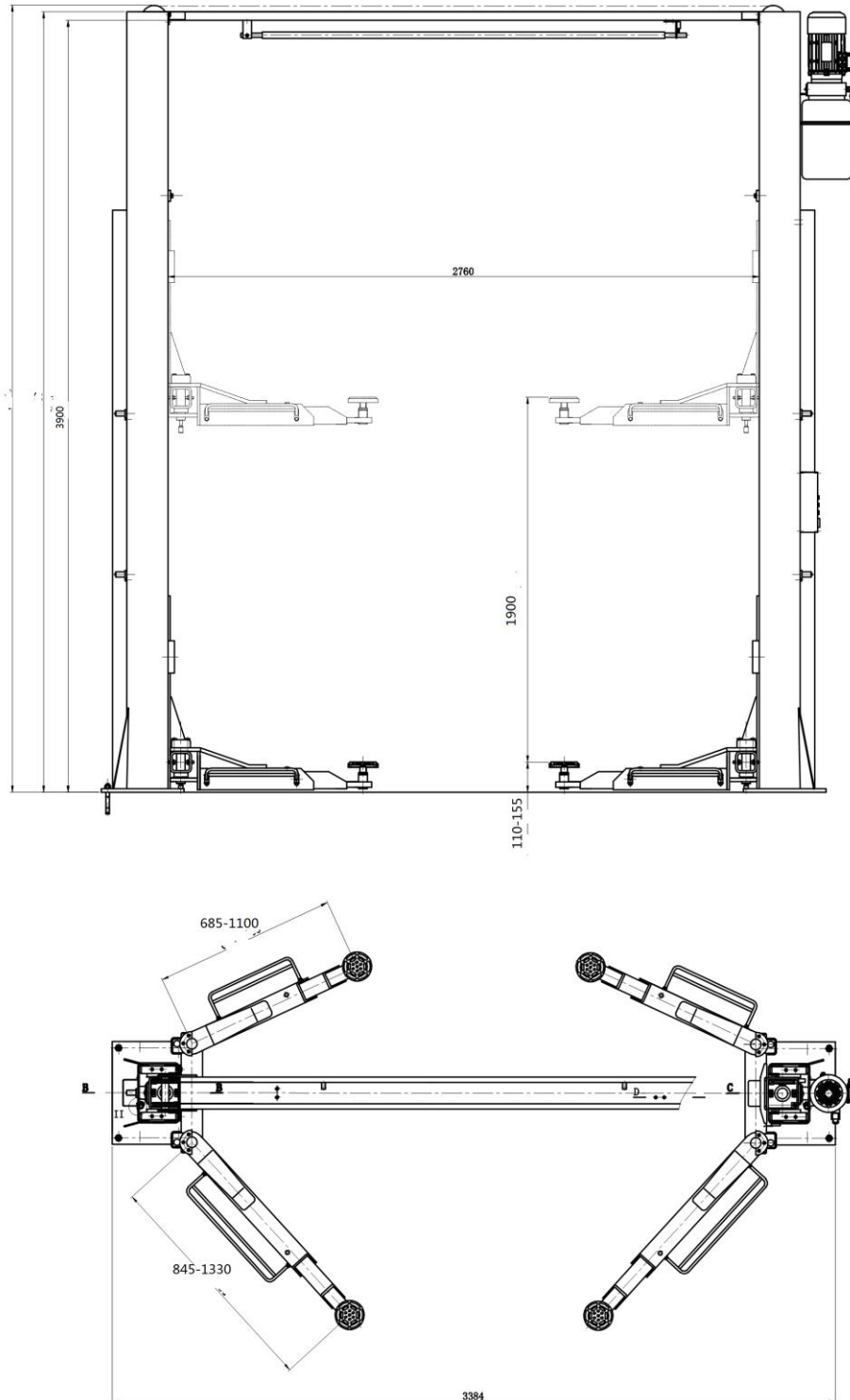

Fig.7 Dimensions and overall clearances

2.1 ELECTRIC MOTOR

	Three-phase	Single phase
Electric motor power rating	2.2KW	2.2KW
Voltage	230-400V3ph.+/-5%	230V1ph.+/-5%
Frequency	50Hz	50Hz
Absorption	230V:11A 400V:6.4A	13A
N°of poles	4	
Speed	1400RPM	1380RPM
Construction	B14	
Insulation class	IP54	IP54
Type	MS90L-4	ML90L-4

The motor must be connected with reference to the attached wiring diagrams.

The motor rotation wise must be the same as shown by the arrow on the pump: if not, modify the electrical connections (see ch.4.INSTALLATION-electric plant connection)

2.2 HYDRAULIC UNIT PUMP

	MOTOR	
	3-PH	Single-ph
Type	R	T
Model	PHC	PHC
Size	7.8cm ³ /g	6.0cm ³ /g
Transmission: coupling type	E32	E32
Continuous operating pressure	160bar	150bar
Maximum operating pressure (peak)	180bar	170bar

2.3 OIL

The oil reservoir contains hydraulic mineral oil in accordance with ISO/DIN 6743/4 with a level of contamination that does not exceed class 18/15 according to ISO 4406, for example **IP HYDRUS OIL 32**; **SHELL TELLUS OIL T32** or equivalent.

2.4 HYDRAULIC OIL DIAGRAM

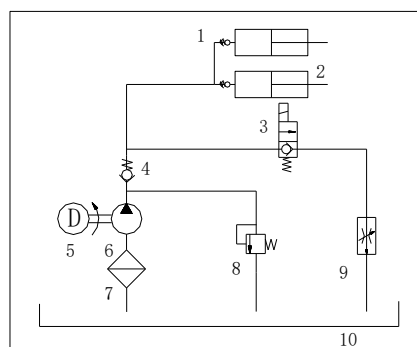

Fig.8 Principle of Hydraulic Part

Ser.	DESCRIPTION
1	Lock valve
2	Operating Cylinder with simple effect
3	Solenoid directional valve
4	Check valve
5	Motor
6	Pump
7	Filter
8	Pressure relief valve
9	Flow control valve
10	Tank

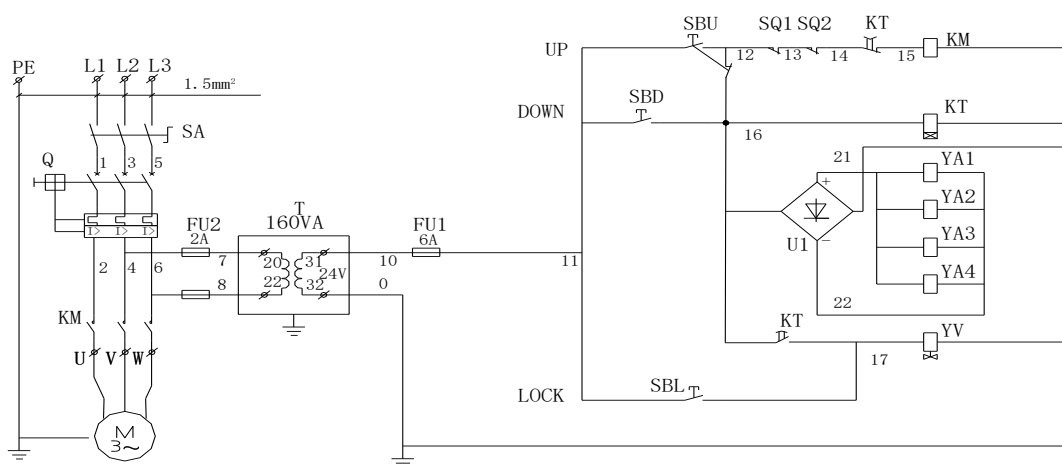

Fig.9 Three -phase wiring diagrams

Ref.	Designation	Type&Specifications	Quantity
SA	Power switch	LW39-16RE04/2	1
Q	Circuit Breaker	DZX2-60L 10/3	1
KM	AC contactor	CJX2-1210	1
M	Motor	MS90L-4 3Phase/400V/1.8kW	1
KT	Time relay	ST3PA-C	1
SQ1	Limit switch	ME 8108	1
SQ2	Safety switch	ME 8104	1
SBL	Lock Pushbutton		1
SBU	Up Pushbutton		1
SBD	Down Pushbutton		1
YA1-YA4	electromagnet	DC 24V	4
YV	Solenoid	AC 24V	1
FU1/FU2	Fuse	RF1-32 (X) 6A/2A	3
T	Control transformer	JBK3-160 400V/24V	1
U1	rectifier	+KBPC10-10-	1

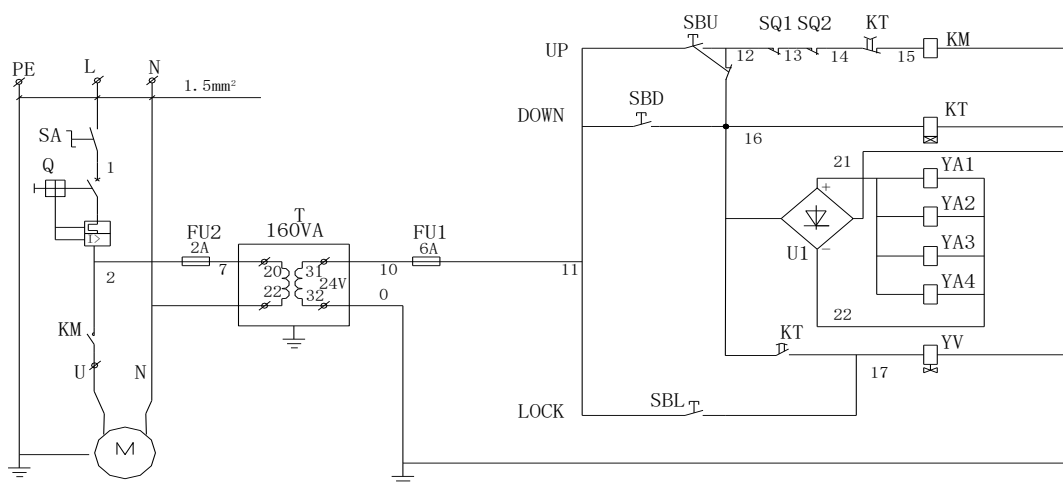

Fig.9a Single-phase wiring diagrams

Ref.	Designation	Type&Specifications	Quantity
SA	Power switch	LW39-16RE04/1	1
Q	Circuit Breaker	DZX2-60L 15/1	1
KM	AC contactor	CJX2-1210	1
M	Motor	ML90L-4 1Phase/220V/1.8kW	1
KT	Time relay	ST3PA-C	1
SQ1	Limit switch	ME 8108	1
SQ2	Safety switch	ME 8104	2
SBL	Lock Pushbutton		1
SBU	Up Pushbutton		1
SBD	Down Pushbutton		1
YA1-YA4	electromagnet	DC 24V	4
YV	Solenoid	AC 24V	1
FU1/FU2	Fuse	RF1-32 (X) 6A/2A	3
T	Control transformer	JBK3-160 220V/24V	1
U1	rectifier	+KBPC10-10-	1

2.5 VEHICLE WEIGHT AND SIZE

Lift rack can be adapted to virtually all vehicles no heavier than 4000kg, the dimensions of which do not exceed the following.

2.6 MAXIMUM DIMENSIONS OF VEHICLES TO BE LIFTED

Max width: 2400mm

Max wheelbase: 3000mm

The underbody of cars with low ground clearance may interfere with the structure of the lift .Pay particular attention in the case of low body sports cars.

Always keep the capacity of the lift in mind in the case of vehicles with particular characteristics.

THE SAFETY area will be determined by the dimensions of the vehicle.

The diagrams below include the criteria for defining the limits of use of the carrack.

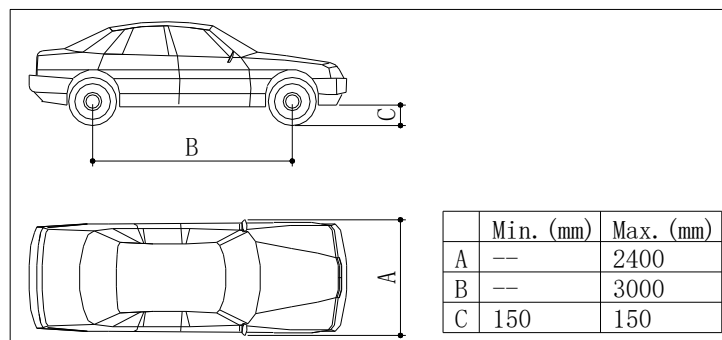

Fig.10 Minimum and maximum dimensions

CHECK MAXIMUM LOAD CAPACITY AND LOAD DISTRIBUTION IN CASE OF LARGER VEHICLES. MAXIMUM WEIGHT OF THE VEHICLE TO BE LIFT

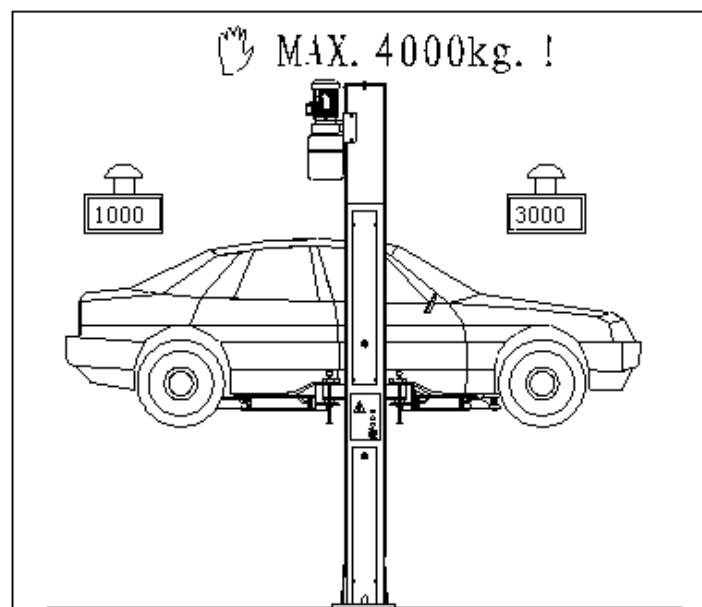

Fig.11 Weight distribution

CHAPTER 3 SAFETY

It is vital to read this chapter of the manual carefully and from beginning to end as it contains important information regarding the risks that the operator and the maintenance fitter may be exposed to in the eventuality that the lift is used incorrectly.

The following text contains clear explanations regarding certain situations of risk or danger that may arise during the operation or maintenance of the lift, the safety devices installed and the correct use of such systems, residual risks and operative procedures to use (general and specific precautions to eliminate potential hazards).

WARNING

Lift is designed and built to lift vehicles and hold them in the elevated position in a closed workshop. All other uses are unauthorized; in particular, the lift is not suitable for:

- Washing and respire work;
- Creating raised platforms or lifting personnel;
- Use as a makeshift press for crushing purpose;
- Use as goods lift
- Use as a jack for lifting vehicles or changing wheels.

THE MANUFACTURE DISCLAIMS ALL LIABILITY FOR INJURY TO PERSONS OR DAMAGE TO VEHICLES AND OTHER PCABLERTY CAUSED BY THE INCORRECT AND UNAUTHORISED USE OF THE LIFT.

During lift and descent movements, the operator must remain in the command station as defined in figure 15. The presence of persons inside the danger zone indicated in the same figure is strictly prohibited. The presence of persons beneath the vehicle during operations is permitted only when the vehicle is parked in the elevated position.

DO NOT USE THE LIFT WITHOUT PROTECTION DEVICES OR WITH THE PROTECTION DEVICES INHIBITED. FAILURE TO COMPLY WITH THESE REGULATIONS CAN CAUSE SERIOUS INJURY TO PERSONS, AND IRREPERABLE DAMAGE TO THE LIFT AND THE VEHICLE BEING LIFTED.

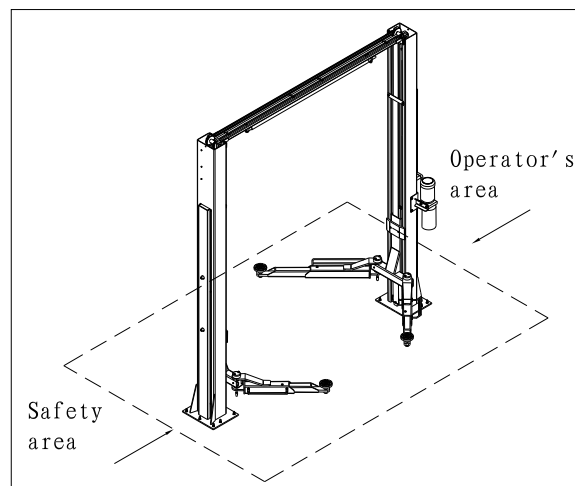

Fig.12 Working Area

3.1 GENERAL PRECAUTIONS

The operator and the maintenance fitter are required to observe the prescriptions of accident prevention legislation in force in the country of installation of the lift.

Furthermore, the operator and the maintenance fitter must:

1. Always work in the scheduled working area as shown in the manual.
2. Never remove deactivate the guards and mechanical, electrical, or other types of safety devices.
3. Read the safety notices affixed to the machine and the safety information in this manual.

In the manual all safety notices are shown as follows:

DANGER: indicates imminent danger that can result in serious injury or death.

WARNING: indicates situations and /or types of maneuvers that are unsafe and can cause injuries of various degrees or death.

CAUTION: indicates situations and /or types of maneuvers that are unsafe and can cause minor injury to persons and /or damage the lift, the vehicle or other psaltery.

3.2 RISKS OF ELECTRIC SHOCK:

Specific safety notice affixed to the lift in areas where the risk of electric shock is particularly high.

3.3 RISKS AND PROTECTION DEVICES

We shall now examine the risks to which the operator and the maintenance fitters may be exposed when the vehicle is immobilized in the raised position, together with the protection devices and adopted by the manufacture to reduce all such hazards to the minimum.

3.4 LONGITUDINAL AND LATERAL MOVEMENT

Longitudinal movement is considered the backward and forward shifting of the load.

Lateral movement implies the shifting to the left or right of the vehicle, especially during the lifting phase on the rack.

These movements can be avoided by positioning the vehicle correctly on the arm disk support plates, which must be previously adjusted to the same height (by loosening or tightening) as the vehicle.

Do not move the vehicle in relation to the arms or adjust arms and disk support plates until the arms have been totally lowered, i.e. the disk support plates must be free from all contact with the vehicle.

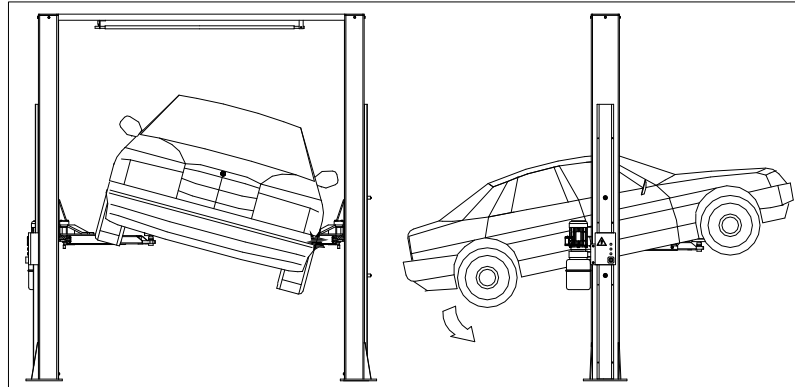

Fig.13 Risk of vehicle fall

 **WARNING**

DO NOT ATTEMPT TO MOVE THE VEHICLE WHEN IT IS RESTING ON THE DISK SUPPORT PLATES.

It is important to position the vehicle on the lift so that the weight is correctly distributed on the arms (Fig.14) for person and equipment safety, it is important that:

1. People rest inside the safety area while the vehicle raising (Fig.12)
2. The engine is off, the clutch engaged and the parking brake pulled.
3. The vehicle is correctly positioned. (Fig.14).
4. Only authorized vehicle (Fig.10-11) are raised without exceeding the rate capacity and overall dimensions.

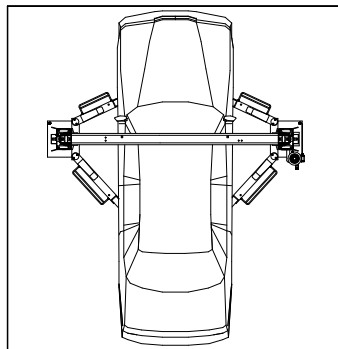

Fig.14 correctly loaded vehicle

3.5 RISKS WHILE THE VEHICLE IS BEING RAISED

The following safety devices have been installed to protect against overweight conditions and equipment failure:

1. The thermal relay in the electric box will trip if the motor is overloaded.
2. The maximum pressure valve (fig.15), located on the hydraulic oil power unit, will trip if the lift is overloaded.
3. In case of a sudden, great leakage in the hydraulic circuit (a broken pipe), the blocking valves, at the bottom of each cylinder, will trip (fig.16).

4. If the lift reaches to the maximum height, push the button to stop it(Fig.17).
5. Keep both cables in balance during raising or lowering (Fig.18).
6. If the hydraulic cylinder breaks, the safety wedges will trip (fig.19), located inside the posts. The wedges are pushed by the spring and immediately stop the carriage preventing their descent.

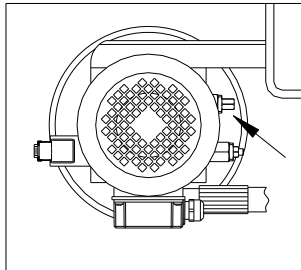

Fig.15

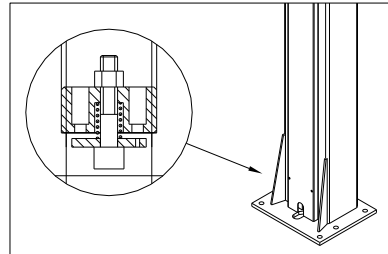

Fig.16

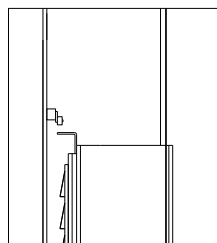

Fig.17

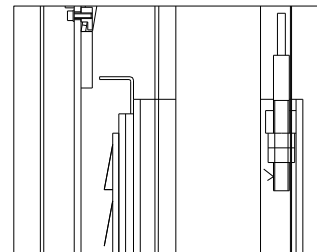

Fig.18

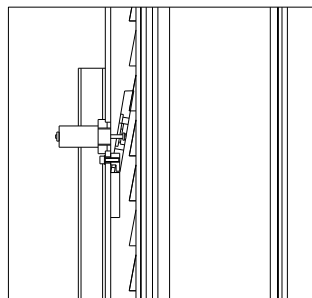

Fig.19

7. If the moving part exceed its travel distance, on the upper part of the command post there is two limit switches connected in series and are usually set working by the “actuator”(fig.17) on the command side carriage. If the first limit switch did not work, the second one would trip after 3sec of carriage run.
8. In case of total breakdown of the limit switches, the carriage will stop a few mm higher, because the hydraulic cylinders come to end stroke, will cause the maximum pressure valve (on hydraulic unit) to trip.

3.6 RISKS OF PERSONS

This paragraph illustrates risks to which the operator, maintenance worker, or any person near the operating area of the lift may be exposed in the case of impeccable use of equipment.

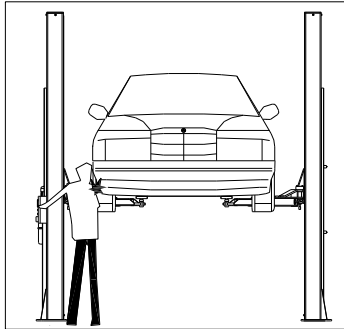

Fig.20

3.6.1 RISK OF CRUSHING (OPERATOR)

Possible if the operator controlling the lift is not in the specified position at the command panel. When the platform and the vehicle are descending, the operator must never be partly or completely underneath the moving structure. During this phase the operator must remain in the command zone (Fig.20).

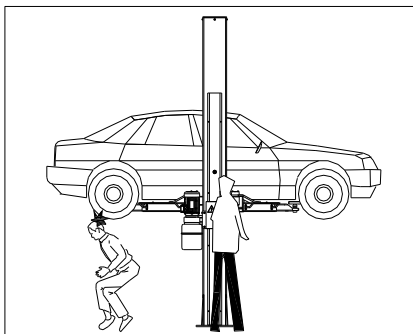

Fig.21

3.6.2 RISK OF CRUSHING (PERSONNEL)

When the platform and the vehicle are descending personnel are prohibited from entering the area beneath the moving parts of the lift. (Fig.21) .the lift operator must not start the maneuver until it has been clearly established that there are no persons in potentially dangerous positions.

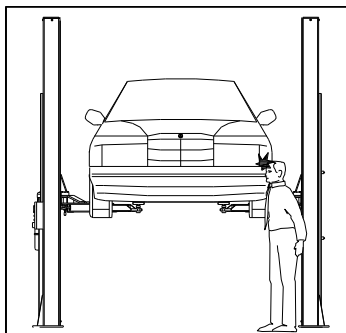

Fig.22

3.6.3 RISK OF IMPACT

Caused by the parts of the lift or the vehicle those are positioned at head height. When, due to operational reasons, the lift is immobilized at relatively low elevations (less than 1.75m from the ground) personnel must be careful to avoid impact with parts of the machine not marked with special hazard coloring (Fig.22).

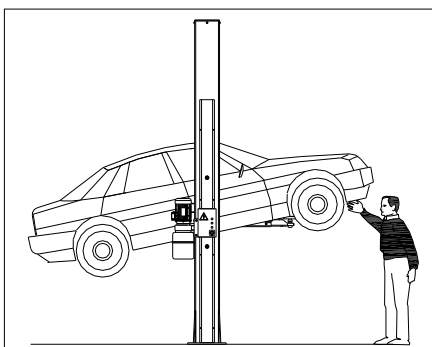

Fig.23

3.6.4 RISK DUE TO VEHICLE MOVEMENT

Movement may be caused during operations, which involve force sufficient to move the vehicle (fig.23). If the vehicle is of considerable dimensions or weight. Movement may lead to overload or unbalancing; all measures must be taking to avoid such an occurrence.

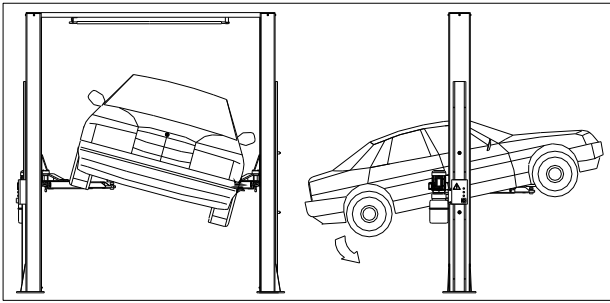

Fig.24

3.6.5 RISK OF VEHICLE FALLING FROM LIFT

This risk could be caused by the incorrect positioning on the arm disk support plates (Fig.24) or in incorrect position of the arm disk support plates in relation to the lift.

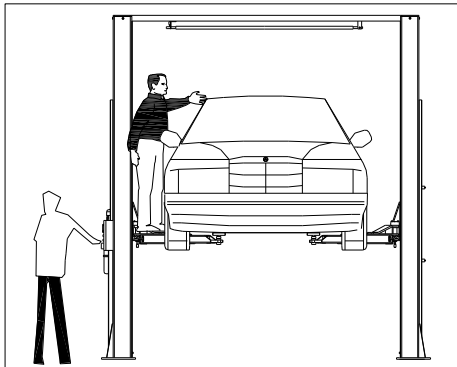

Fig.25

NEVER BOARD THE VEHICLE AND/OR TURN THE ENGINE ON WHEN LIFT IS RAISED (FIG.25)

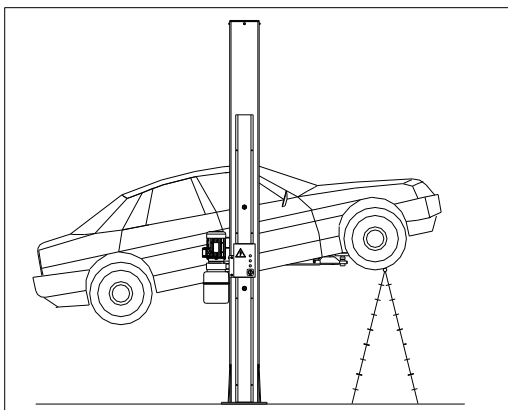

Fig.26

NEVER LEAN OBJECTS AGAINST THE POSTS OR LEAVE THEM IN THE AREA WHERE MOVING PARTS ARE LOWERED.

This could hamper lowering or cause the vehicle to fall from the rack (Fig.26)

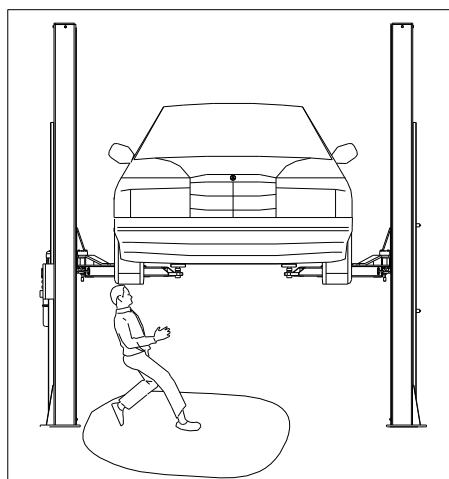

Fig.27

3.6.6 SLIPPING

This risk may arise due to spillage of lubricants in the surrounding area (fig.27).

ALWAYS KEEP THE AREA SURROUNDING THE LIFT CLEAN BY REMOVING ALL OIL SPILLS.

To avoid the risk of slipping, make use of the recommended personal protection (anti-slip footwear).

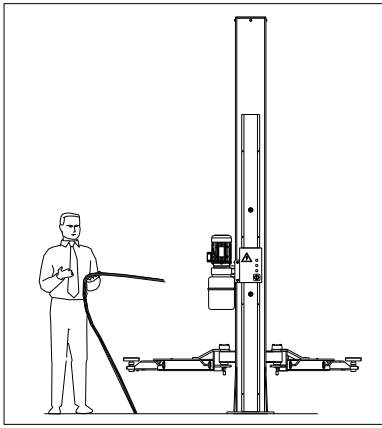

Fig.28

3.6.7 RISK OF ELECTRIC SHOCK

Risk of electric shock in areas of the lift housing electric wiring. Do not use jets of water, steam (high pressure wash units), and solvents Or paint in the immediate vicinity of the lift, and take special care to keep such substances clear off the electrical command panel (fig.28).

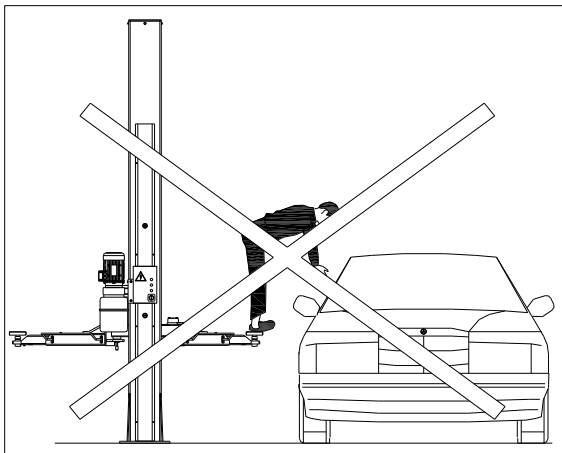

Fig.29

3.6.8 RISK OF COMPONENT FAILURE DURING OPERATION.

The manufacturer has used appropriate materials and construction techniques in relation to the specified use of the machine in order to manufacture a reliable and safe lift. Note however, that the lift must be used in conformity with the manufacturers prescriptions and the frequency of inspections and maintenance work recommended in chapter 6 "MAINTENANCE" must be observed.

3.6.9 RISK RELATED TO IMPROPER USE

Persons are not permitted to stand or sit on the platforms during the lift maneuver or when the vehicle is already lifted(fig.29). All uses of the lift other than the uses for which it was designed are liable to give rise to serious accidents involving the persons working in the immediate vicinity of the unit. It is therefore essential to adhere scrupulously to all regulations regarding use, maintenance and safety contained in this manual.

3.7 SAFETY INSTRUCTINS FOR SERVICING

1. Maintenance or repair work by authorized service personnel only.
2. Turn off and padlock the main switch before doing any maintenance, or repair work.
3. Work on pulse generators or proximity switches by authorized service personnel only.
4. Work on the electrical equipment by certified electricians only.
5. Do not replace or override the safety devices.
6. Ensure that ecologically harmful substances are disposed of only in accordance with the appropriate regulations.

CHAPTER 4 INSTALLATION

THE FOLLOWING OPERATIONS MUST BE PERFORMED EXCLUSIVELY BY SPECIALISED TECHNICAL STAFF WITH AUTHORISATION FROM THE MANUFACTURER OR LICENSED DEALER. IF THESE OPERATIONS ARE PERFORMED BY OTHER PERSONS, SERIOUS PERSONAL INJURY AND/OR IRREPERABLE DAMAGE TO THE LIFT UNIT MAY RESULT.

4.1 INSTALLATION REQUISITE CHECKLIST

The lift is designed for installation in enclosed areas suitably protected from the weather. The place of installation must be well clear of areas destined to washing or painting, and away from solvent or paint storage areas or areas where there is a risk of potentially explosive atmosphere.

SUITABILITY OF THE DIMENSIONS OF THE PLACE OF INSTALLATION AND SAFTY CLEARANCE.

The lift must be installed in observance of the clearances between walls, pillars, other machines, etc. indicated in figure 30 and in compliance with any legislative requirements in the county of installation.

Check in particular:

1. Minimum height: 5000mm inclusive of height of vehicle, maximum height of arms,(i.e. 1900mm), and upper post height (i.e.2828mm)
2. minimum distance from walls: 600mm
3. Minimum working area: 700mm
4. Area for command station
5. Area for maintenance, access and emergency escape routes.
6. Position in relation to other machines
7. Proximity to power supply for trouble-free hook-up

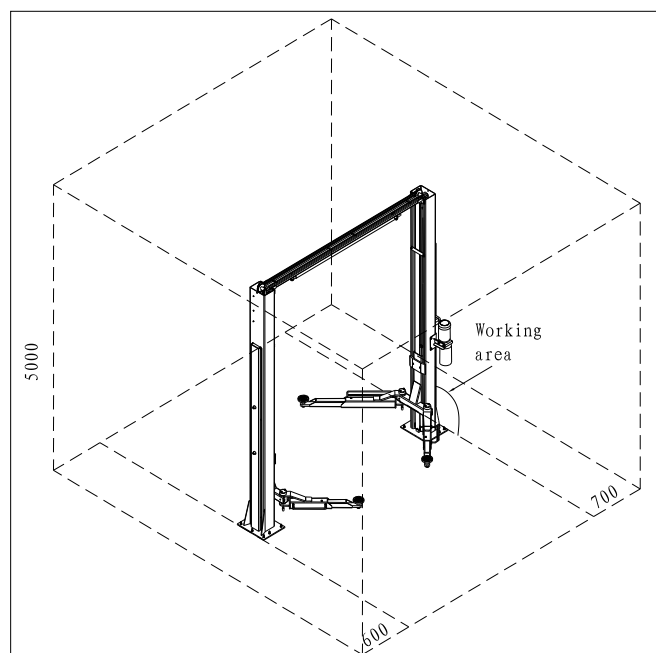

Fig. 30

4.2 LIGHTNING

All parts of the machine must be uniformly lit with sufficient light to assure that the adjustment and maintenance operations specified in the manual can be performed, and without areas of shadow reflected light, glare and avoiding all situations that could give rise to eye fatigue.

The lighting must be installed in accordance with the laws in force in the place of installation (responsibility lies with the lighting equipment fitter)

4.3 FLOOR

The lift must be installed on a horizontal concrete bed with a minimum thickness of 200mm built and a resistance $\geq 30\text{N/mm}^2$.

The floor must also be flat and level (10mm of tolerance for leveling). Consult the manufacturer with regard to special applications.

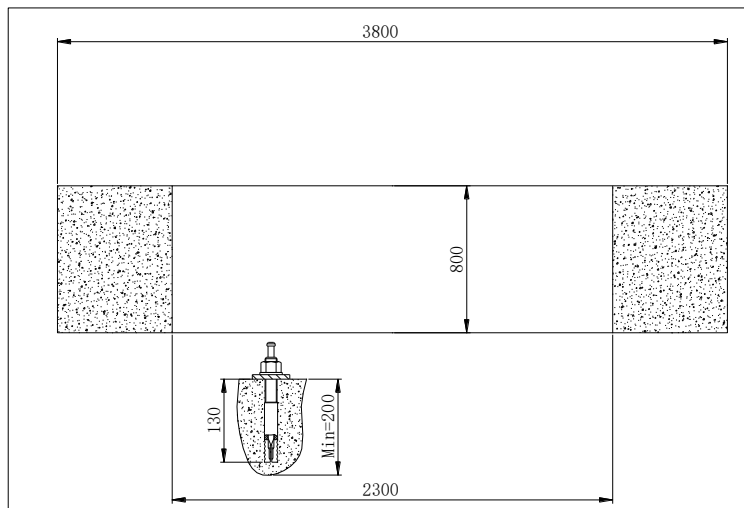

Fig.31

4.4 ASSEMBLING

WARNING

DURING INSTALLATION ONLY AUTHORISED PERSONNEL IS ALLOWED

To assemble the lift, the weight of the various parts is to be considered, in order to provide a lifting machine with the minimum capacity 500kg

Max. Lifting height 2900mm

Before starting to assemble the lift, check the crate contains all the needed material.

4.4.1 PUT COLUMN

1. Position the base plate of both column of which the open side should be inner side oriented. Make sure the distance from up to bottom should be 2760mm. The thickness of the spacer is over 300mm to ensure the operation of installing safety devices, cables, oil pipe and wire.
2. Install safety devices, which including solenoid, self-locking board and hook according to fig.33.

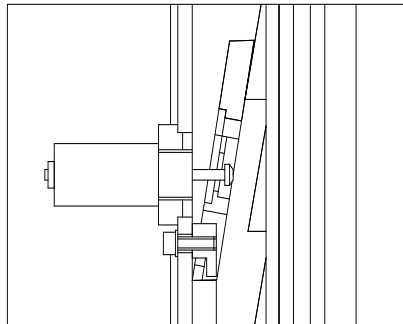

Fig.33

3. Connect crossbeams to both columns to both columns to fig.34. (Notice that the limited switched is inside the main column)

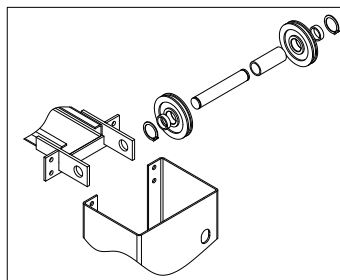

Fig.34

4. Install the safety bar according to fig.35 and fig.36.

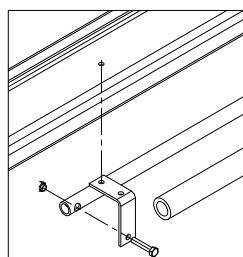

Fig.35

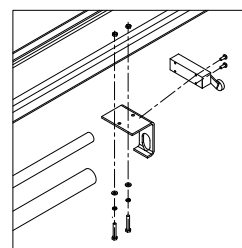

Fig.36

5. Install the synchronization cable according to fig.37.

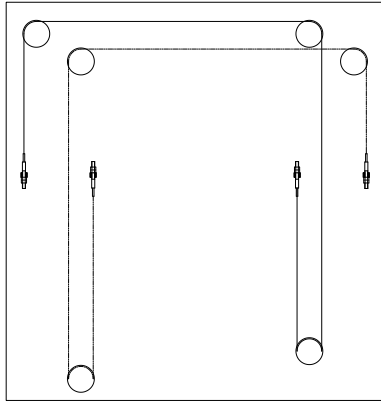

Fig.37

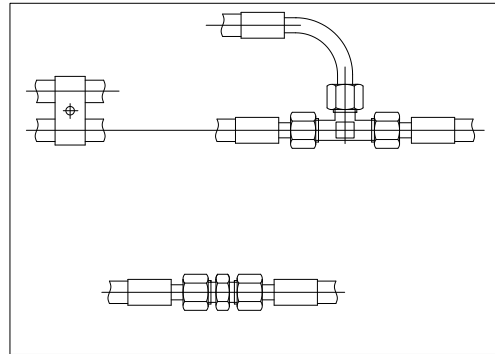

Fig.38

6. Connect the long hose inside both columns according to fig.40, tighten (upside connect to main column and the down side connect with sub-column), and then fix the oil pipe by using clip.
7. Install the electrical box on the main column and then cross all the wires through holes and connect with limited switch and solenoid.
8. Put up the main column (Notice that the carriage engages in the ratchet and keep in the same height). Adjust the uprightness of the column and install the expansion bolt according to fig.32.
9. Adjust two balance cables.

4.4.2 HYDRAULIC PLANT

1. Connect the pump on the connecting board according to fig.41 and then fix on the main column.
2. Connect the hydraulic unit to the circuit crossing with a flexible pipe(Fig.40).
3. Tight all the fittings very well, even the one already mounted by the manufacturer.
4. Full the hydraulic unit tank with 8 liters of hydraulic oil **ISO 32** as **IP HYDRUS OIL 32, SHELL TELLUS OIL T32** or similar (See Ch.2, Technical specifications).
5. Remove the oil filling cap and substitute it with the given drain cap.

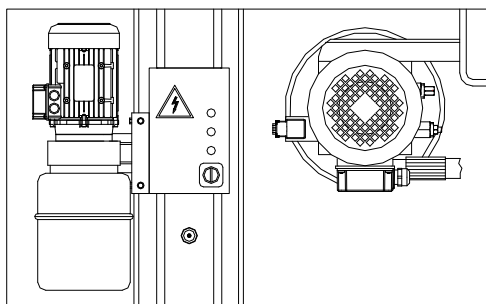

Fig.39

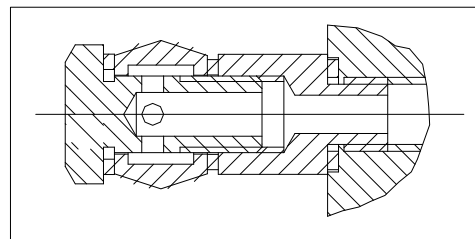

Fig.40

4.4.3 ELECTRIC PLANT CONNECTION



The operations listed below must be performed by skilled personnel

- 1) Before connecting the electric system, make sure that:
 1. The power supply plant to the lift is equipped with the protection device required by current standards in the country where the machinery is installed.
 2. The power supply line has the following cross-section:
 - Lift voltage 400V, three-phase.....minimum 2.5mm²
 - Lift voltage 230V, three-phase.....minimum 4mm²
 - Lift voltage 230V, single-phase.....minimum 6mm²
 3. The voltage oscillations are within the tolerance range set forth by the specifications.

The manufacturer supplies the rack to operate at 400V with a three-phase configuration; if the line voltage is different, the motor and transformer connection must be changed (Fig.41) it is also necessary to replace the thermal relay requesting that part from the manufacture and/or service center.
- 2) Connect the power and control system to the terminal strip on the control box (Fig.42) , inserting the cable into the rack passing through the prepared hole and following the wiring diagram on pages 13.
 1. Install the electrical box on the main column.
 2. Connection the limit switches.
 3. Complete the solenoid valve (on the hydraulic unit) connection.
 4. Connection the electromagnets.
 5. Connect the electric motor.
 6. Complete the voltage and command connections to the control panel clamp box.
- 3) Tight the wires by using nylon tie, and then fix by clip.

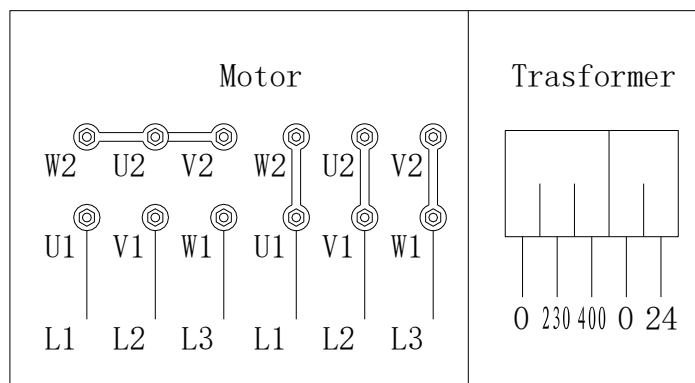

Fig.41

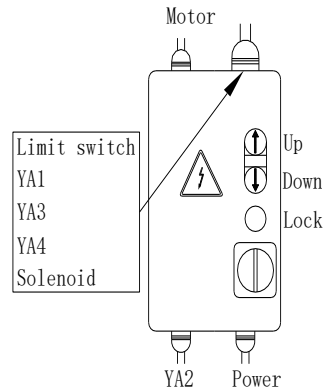

Fig.42

- 4) Close the cover of the electric box, turn the main switch to position 1, press the up push button (Fig.42) ,The motor rotation wise should be the one shown by the arrow on the pump.

BEWARE: The pump rotating for a long time in the wrong sense may cause itself serious damages.

- 5) Make sure that the post end limit switches work properly by pressing them manually.

4.4.4 ARM ASSEMBLING

1. Press the up push button, raise the carriages to a height of about 70cm off the ground, then press the lock push button, **SET THE MAIN SWITCH (IG) TO POSITION 0 AND CUT OFF THE POWER SUPPLY TO THE LIFT.**
2. Grease the holes $\phi 40$ on the arms ends.
3. Mount the arms into the carriage supports and inset the dowel pins into the support holes as shown in fig.31 and fig.43. Notice the entrance of driving should be the same as entrance of arms.
4. Block the spring ring at the end of the pin.
5. It is important to install the screw inside the arm locking.

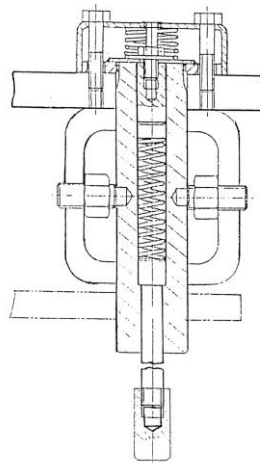

Fig.43

 **WARNING**

End-user should confirm that the over load device must be connected before the electrical power connected to lift.

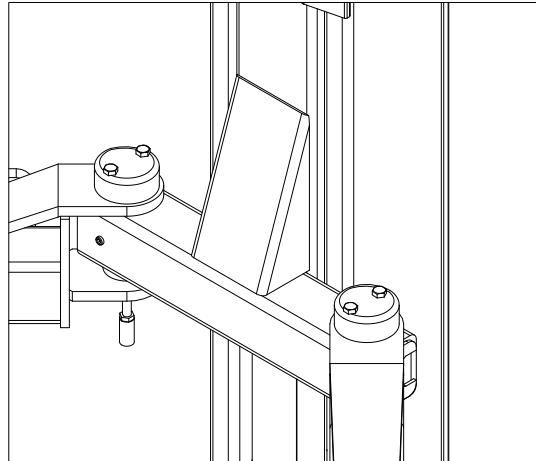

Fig.43a

4.4.5 INSTALL THE COVER PLATE

Two plates have been installed at the column by 8 pieces M8×16 bolts.

4.5 TESTING AND CHECKS TO PERFORM BEFORE START-UP

4.5.1 MECHANIAL TESTS

1. Attachment and tightness of bolts, fittings and connections
2. Free sliding of moving parts
3. Clean state of various parts of the machine
4. Position of the protection device
5. Arms blocking device

4.5.2 ELECTRIC TESTS

1. Connection comply with diagrams
2. Machine earth connections

4.5.3 OPERATING OF THE FOLLOWING DEVICES

1. Rise limit switch
2. Security device electromagnets
3. Hydraulic oil plant solenoid-valve

4.5.4 HYDRAULIC OIL TEST

1. Sufficient oil in the tank
2. No leaks
3. Cylinder operation

NOTE: If oil is not present, fill the reservoir of the power unit with the necessary amount of oil .See the procedure in chapter 6: MAINTENANCE

4.5.5 ROTATION DIRECTION TEST

The motor should turn in the direction of the arrow located on the power unit pump; check using brief start-ups (each start-up must last a maximum of two seconds). If problems arise in the hydraulic oil plant, see the "Trouble-shooting" table in chapter 7

4.6 SET UP

WARNING

THESE OPERATIONS MUST ALWAYS BE PERFORMED BY TECHNICIANS OF THE AUTHORIZED SERVICE CENTRE INDICATED IN THE FRONT OF THIS MANUAL

4.6.1 VACUUM TEST (without vehicles loaded)

In this phase check the following:

- . That the up, down and lock push buttons operate correctly;
- . That the rack reaches the maximum height;
- . That there are no abnormal vibrations in the posts and in the arms;
- . That the safety wedges enter the iron pads under the carriage
- . That the rise limit switches trip
- . That the electromagnet trips
- . After having done all as previously recommended, the height difference between the arms of the two carriages is less than 1cm. On the contrary, adjust their level by working on the counter nuts on the synchronous steel cables

To perform the tests listed above, complete two or three complete up and down cycles. This is also to be done in order to make the air in the hydraulic circuit going out.

4.6.2 LOAD TESTS

Repeat the previous tests with the vehicle on the rack

After the load tests, visually inspect the machinery and check again that all bolts are tightened.

CHAPTER 5 OPERATIONS AND USE

The lift Commands (control devices) is shown as Fig. 30.

CONMANDS

5.1.1 MAIN SWITCH (IG)

POSITION 0:

The lift is not energized. It is possible to access the interior of the box and lock the switch to prevent use of the lift.

POSITION 1:

This energizes the lift and lock the door of the box to prevent it from being opened accidentally.

5.1.2 UP PUSH BUTTON

“Man present” type, it operates under 24V and if pressed, activates the electric motor and mechanisms that lift the carriage.

5.1.3 DOWN PUSH BUTTON

“Man present” type, it operates under 24V and if pressed, activates the safety wedge electromagnets and the power unit exhaust valve.

5.1.4 LOCK PUSH BUTTON

“Man present” type, it operates under 24V and if pressed, activates the oil discharge electro-valve in the hydraulic power unit and it deactivates the electromagnets, placing the load in the parking position on the safety wedges.

5.2 OPERATING SEQUENCE

Position the lift arms in the hold points prescribed for the vehicle, adjusting the disks to the same height.

Each time the carriages are brought down to the ground, check the position of the disks under the chassis of the vehicle before raising the carriages again.

5.2.1 LIFTING

Turn the main switch (IG) to the position 1 and press the up push button until reaching the required height. As the carriages are raised the safety wedges are inserted automatically into each the iron pad under the carriage. Regarding lift limits and safety devices, see pages 17, 18 **“RISKS WHILE**

THE VEHICLE IS BEING RAISED”.

5.2.2 PARKING

Once the required height has been reached, press the lock push button. The movement is stopped automatically when the safety wedge rests on the level of the first slot that they come in contact with while the carriages are coming down.

5.2.3 LOWERING

Before lowering the carriages, the safety wedges must be disconnected. Press the down push button that the carriage will be lift about 3-cm, then automatically releases the safety wedges and activates the down electro-valve. Lowering speed is regulated by the “flow regulating valve” in the pump. Lowering stops when the hydraulic cylinders are completely unloaded. When the carriages are totally lowered, the automatic arm-blocking device opens and lets the carriages rotate.

CHAPTER 6. MAINTENANCE

PRECAUTIONS

WARNING

Maintenance must be carried out **ONLY BY SKILLED PERSONNEL WHO ARE VERY FAMILIAR WITH THE LIFT.**

When performing maintenance on the lift, follow all the necessary precautions to **PREVENT THE LIFT FROM BEING STARTED ACCIDENTALLY:**

1. The main switch on the control box must be locked in **POSITION 0** by using a **LOCK**.
2. **THE KEY** for the lock must be kept by the **MAINTENANCE FITTER.**
3. While maintenance is being performed on the machine, always keep in mind all the main possible risks and the safety instructions indicated in chapter 3 “safety risk of electric shock” at the machine power supply terminal strip.

IT IS PROHIBITED TO PERRORM MAINTENANCE ON AND LUBRICATES MOVING PARTS.

IMPORTANT

To ensure cable maintenance.

1. Only use original spare parts and tools that are suitable for the job and in good condition;
2. Follow the maintenance schedule indicated in the manual: these frequencies are indicative and must always be considered as general rules to be respected.
3. Good preventive maintenance requires constant attention and continuous supervision on the machine. Quickly find the cause of any abnormalities such as excessive noise, overheating, leaking fluids, etc.

Special attention is required for:

1. The condition of lifting parts (cylinder, power unit);
2. Safety devices (micro switches, electromagnets and safety wedges)

To perform maintenance correctly, refer to the following documents supplied by the rack manufacturer:

1. Complete functional diagram of the electric equipment and auxiliary equipment indicating the power supply connections
2. Hydraulic diagram with lists of parts and max. pressure values
3. Exploded drawings with the data needed to order spare parts
4. List of the possible causes of malfunctions and recommended solutions (chapter 7 of the manual)

6.2 PERIODIC MAINTENANCE

6.2.1 OPERATION FREQUENCY

To keep the lift working at full efficiency, follow the indicated maintenance schedule. The manufacturer will not be responsible and will not honor the warranty as a result of non-compliance with the instructions indicated above.

NOTE

The frequency indicated refers to normal operating conditions; different frequencies will apply to particularly server conditions.

ALL MAINTENANCE OPERATIONS MUST BE PERFORMED WITH THE LIFT STOPPED AND THE MAIN SWITCH KEY LOCKED.

When after the machine has been installed, check:

- 1 The tightness of the posts bases connection anchor bolts
- 2 The tightness of the beam to posts attachment screws
- 3 That the opposite carriages arms are at the same level
- 4 The power unit oil level. Add oil up to the right level, if necessary

6.2.2 EVERY MONTH

HYDAULIC POWER UNIT

- 1 Check the oil level, using the special dipstick, which is attached to the filler cap. If necessary, add oil through the cap to reach the required level. For the type of oil, see page 12 "**TECHNICAL SPECIFICATIONS**".
- 2 After the first 40 hours of operation, check if the conveyer or filter is clogged and the oil contamination level. (Clean the filter and replace the oil if there is a high contamination level).

HYDRAULIC CIRCUIT

Check that there are no oil leaks in the circuit between the power unit and cylinder and in the cylinder itself. In this case, check the condition of the gaskets and replace them, if necessary.

6.2.3 EVERY 3-MONTH...

HYDRAULIC PUMP

Under normal operating conditions, check that there is no changes in the noise in the power unit pump and check that the relative bolts are properly tightened.

SYNCHRONOUS SYSTEMS

- 1 Check the operating condition and efficiency of the safety devices (as described at pages 17, 18) and the wear on the safety wedges and relative hinge pins. Oil the pins on the safety wedges. In case of excessive wear, replace the safety wedges and/or pins.
- 2 Use a torque wrench to check that the post bases anchor bolts screws are properly tightened to the ground as well as the connection bolts.
- 3 Clean and lubricate the carriage side runners and guides.
- 4 Check that all screws are tightened
- 5 Check that the arm locking system works properly.
- 6 Grease all the moving parts.

6.2.4 EVERY 6-MONTH...

HYDRAULIC

Check the contamination or aging level of the oil. Contaminated oil is the main cause of malfunctions of the valves and leads to a brief service life of the gear pumps.

SYNCHRONOUS CABLE

Check the pulleys and pulley races conditions. Control the cable wear by checking diameter, possible broken wires, other damages or relevant changes. With a paintbrush grease the cable in order to avoid corrosion or breakage due to oxidation.

6.2.5 EVERY 12-MONTH...

General check: visual inspection of all structural parts and mechanisms to guarantee that there are no problems or anomalies.

Electric plant: skilled electricians (contact the service center) should test the electric plant, including the motor of the power unit, cables, and limit switch and control box.

HYDRULIC PLANT OIL

Replace the oil, following the instructions listed below:

1. Lower the lift to the minimum height (on the ground)
2. Make sure that the hydraulic cylinder is at the end of its travel
3. Disconnect the power supply to the lift rack.
4. Drain the oil from the hydraulic circuit, unscrewing the plug located at the bottom of the power unit reservoir.
5. Close the drain plug
6. Fill the power unit with oil through the plug located at the top of the power unit reservoir.

The oil must be filtered

Oil characteristics and types are reported in the technical specifications (chapter.2, page 14)

1. Close the filler plug
2. Energize the lift rack
3. Go through two or three up-down cycles (for a height about 20-30 centimeters) to insert oil into the circuit.

When changing the oil: use only recommend oil or the equivalent; do not use deteriorated oil that has been in the warehouse for an extended period of time. Oil should be disposed as indicated in appendix "A", page 37.

AFTER EACH MAINTENANCE OPERATION, THE MACHINE MUST RETURN TO ITS INITIAL CONDITIONS, INCLUDING THE DISASSEMBLED PROTECTION AND SAFETY DEVICE.

To ensure good maintenance, it is important:

1. To sue only tools that are suitable for the job and original spare parts
2. Follow the minimum maintenance schedule as indicated
3. Immediately find the cause of any abnormalities (excessive noise, overheating, leaking fluids, etc)
4. Pay special attention to lifting parts (cylinders) and safety devices
5. Use all the documentation supplied by the manufacturer (wiring diagrams, etc)

6.3 PERIODIC LUBRIFICATION CHART

Lubricate the rack as indicated in Fig.46. Grease must be taken from perfectly closed tins and/or well preserved. Old or damaged grease may damage the lubricated part.

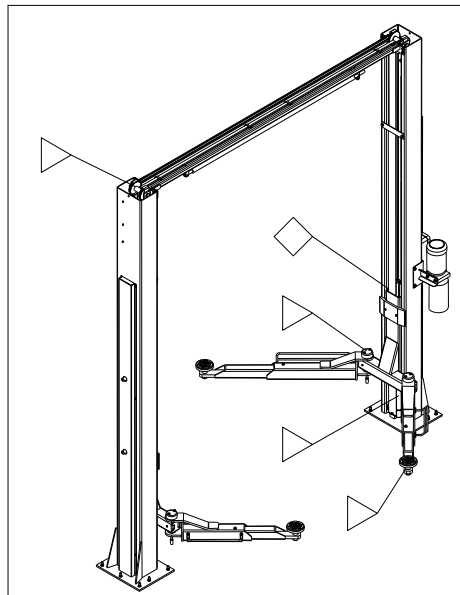

Fig.44

△ Lubricate every three months

□ Lubricate every six month

CHAPTER 7 TROUBLESHOOTING

7.1 TROUBLESHOOTING GUIDE

Troubleshooting and possible repairs require absolute compliance with **ALL THE SAFETY PRECAUTIONS** indicated in chapter 6 “**MAINTENANCE**” and chapter 3 “**SAFETY**”.

7.2 POSSIBLE PROBLEMS AND SOLUTIONS

Problem	Possible cause	Solution
The lift does not rise when the pushbutton is pressed (motor does not run)	Burnt fuse Line current does not arrive Malfunction in the electric plant: -Broken limit switch -burnt motor	Replace fuse Connect again Call Service Center
The lift does not rise when the pushbutton is pressed (motor runs)	Not enough oil Drain solenoid valve opened Max pressure valve working Leaks in the hydraulic circuit	Top un oil level Check electric connections or change it Take load down Repair the hydraulic circuit
Lift continues to rise after having released the up pushbutton	Faulty pushbutton	Unplug the lift and call Service Center
Lift does not descend	Forging object Solenoid valve blocked Malfunction in the electric plant Carriages still lean on security devices Block valves have tripped	Remove object Change it (call Service Center) Call Service Center Make the correct descent sequence Repair the hydraulic circuit damage
The lift does not rise to the maximum height	Oil is not enough Vehicle has tripped the end of-stroke bar	Add oil into the power unit oil tank This working is correct
After having released the up push button, the lift stops and lowers slowly	Drain valve dose not close because it is dirty Defective drain valve	At the same time set the rise and descent movements, to clean the valve Change (call Service Center)
The power unit motor overheats	Motor malfunction Wrong voltage	Call Service Center Check voltage
Power unit pump is noisy	Dirty oil Wrong assembling	Change oil Call Service Center
Oil leakage from cylinder	Damaged gaskets Dirt in the plant	Change the damaged gaskets Clean all parts Check the valves are not damaged

APPENDIX A-SPECIAL NOTES

A.1 DISPOSAL OF USED OIL

Used oil, which is removed from the power unit and the plant during an oil change, must be treated as a polluting product, in accordance with the legal prescriptions of the country in which the lift is installed.

A.2 MACHINE DEMOLITION

DURING MACHINE DEMOLITION, COMPLY WITH ALL THE SAFETY PRECAUTIONS DESCRIBED IN CHAPTER 3, WHICH ARE ALSO VALID FOR ASSEMBLING.

The machine must be demolished by authorized technicians, just like for assembling. The metallic parts can be scrapped as iron. In any case, all the materials deriving from the demolition must be disposed of in accordance with the current standards of the country in which the rack is installed. Finally, it should be recalled that for tax purposes, demolition must be documented; submitting claims and documents according to the current laws in the country in which the rack is installed at the time the machine is demolished.

APPENDIX B SPARE PARTS

B.1 SPARE PARTS

When replacing parts and making repairs, comply with ALL THE SAFETY PRECAUTIONS described in chapter 6 MAINTENANCE and in chapter 3 SAFETY

Take all the necessary precautions to **AVOID ACCIDENTAL START-UP OF THE LIFT**

1. The switch on the control box must be blocked in position 0 with a lock
2. The key of the lock must be kept by the maintenance fitter during the maintenance operation.

B.2 PROCEDURE FOR ORDERING SPARE PARTS

To order spare parts:

1. Indicate the serial number of the lift and the year built
2. Indicate the quantity required.

The request must be submitted to the authorized reseller as indicated in the front of the manual.

B.3 SPARE PART

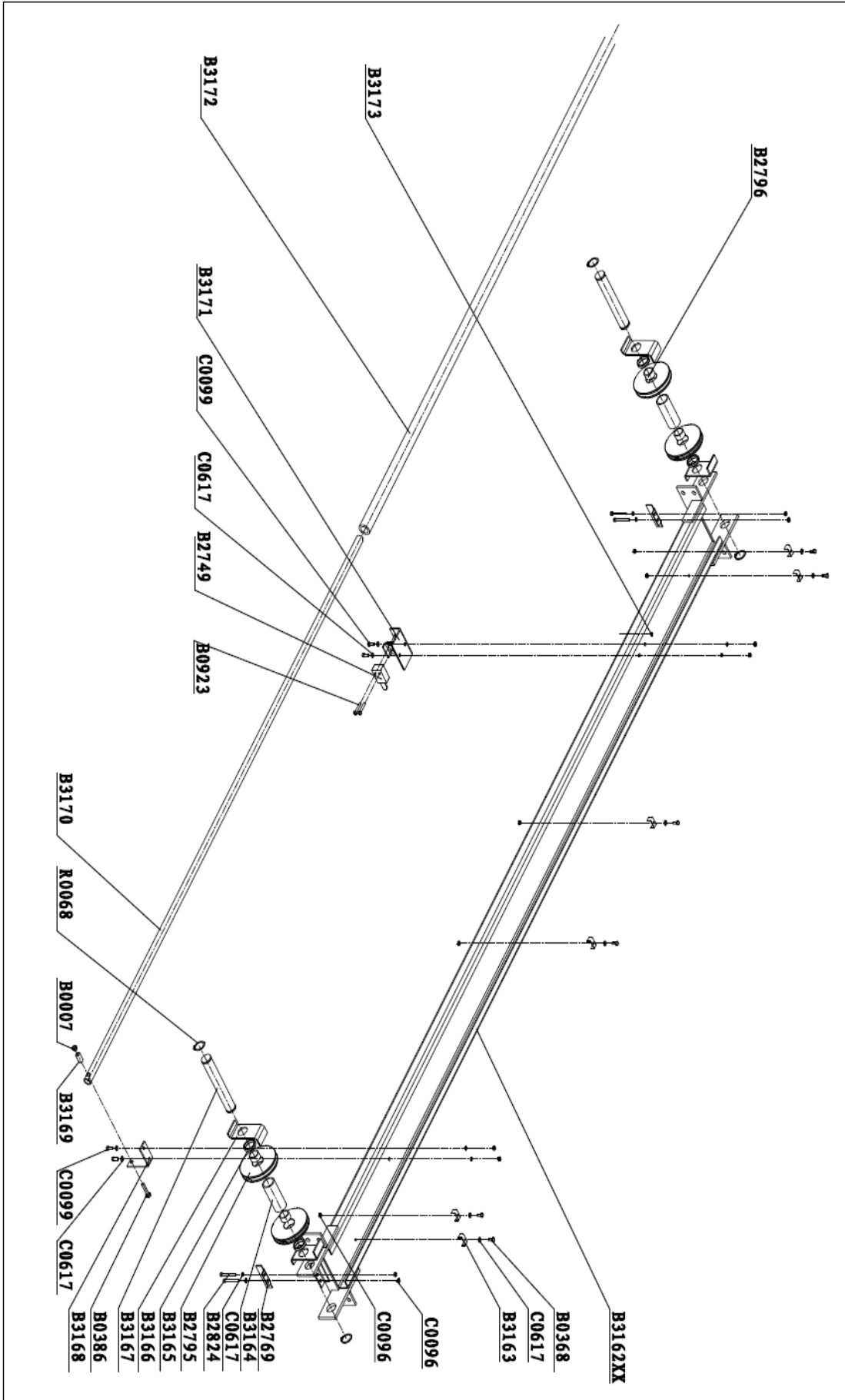

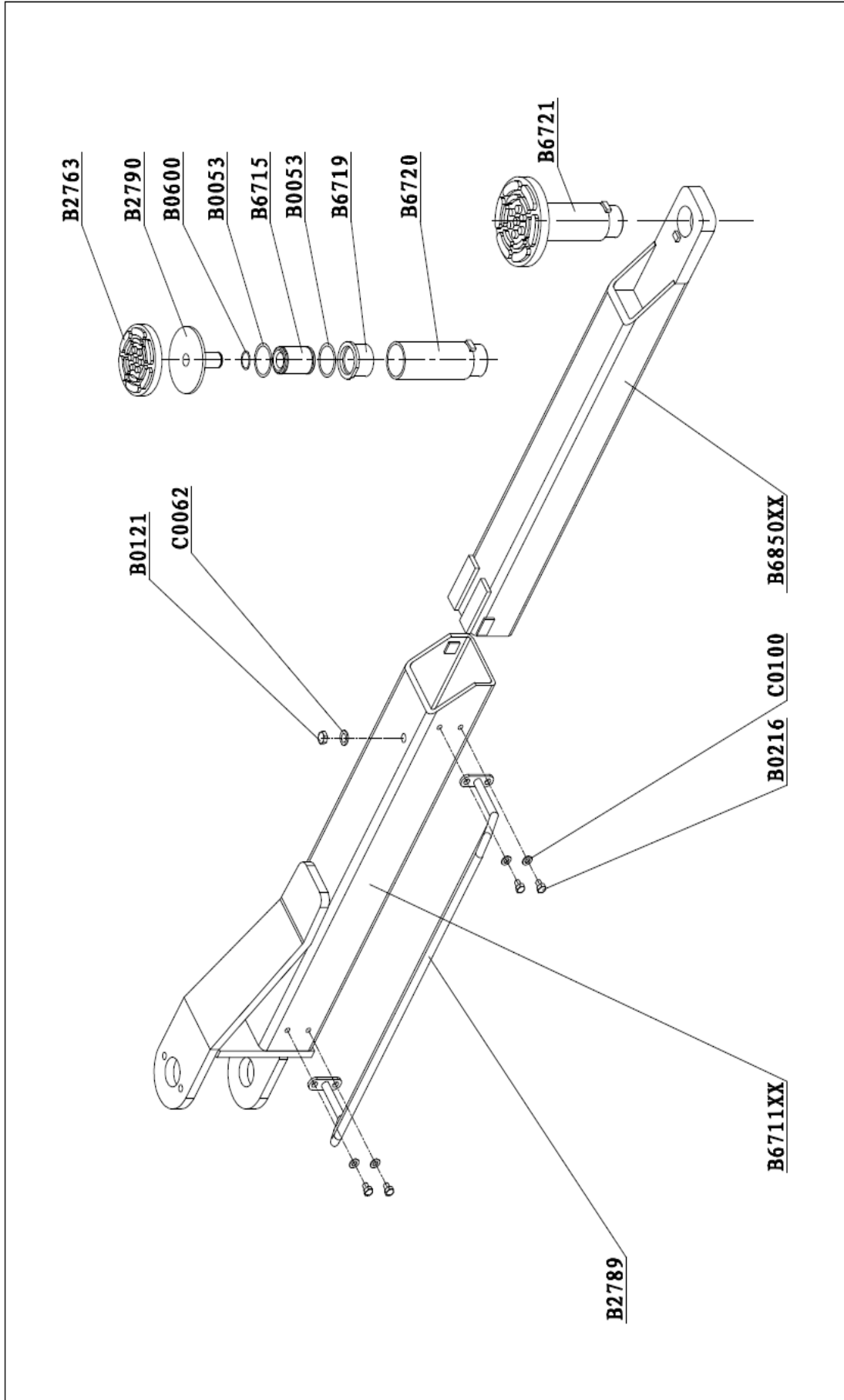

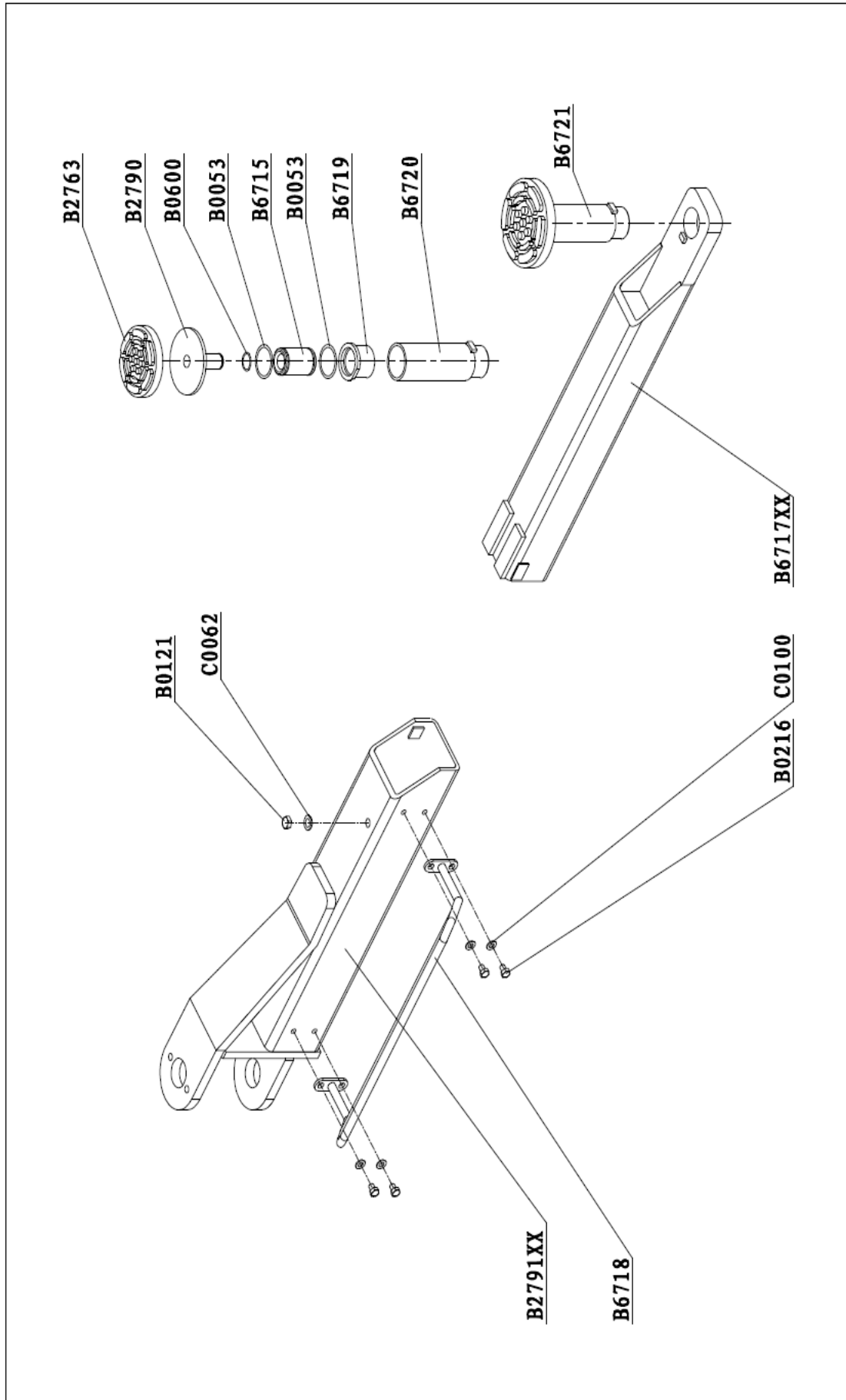

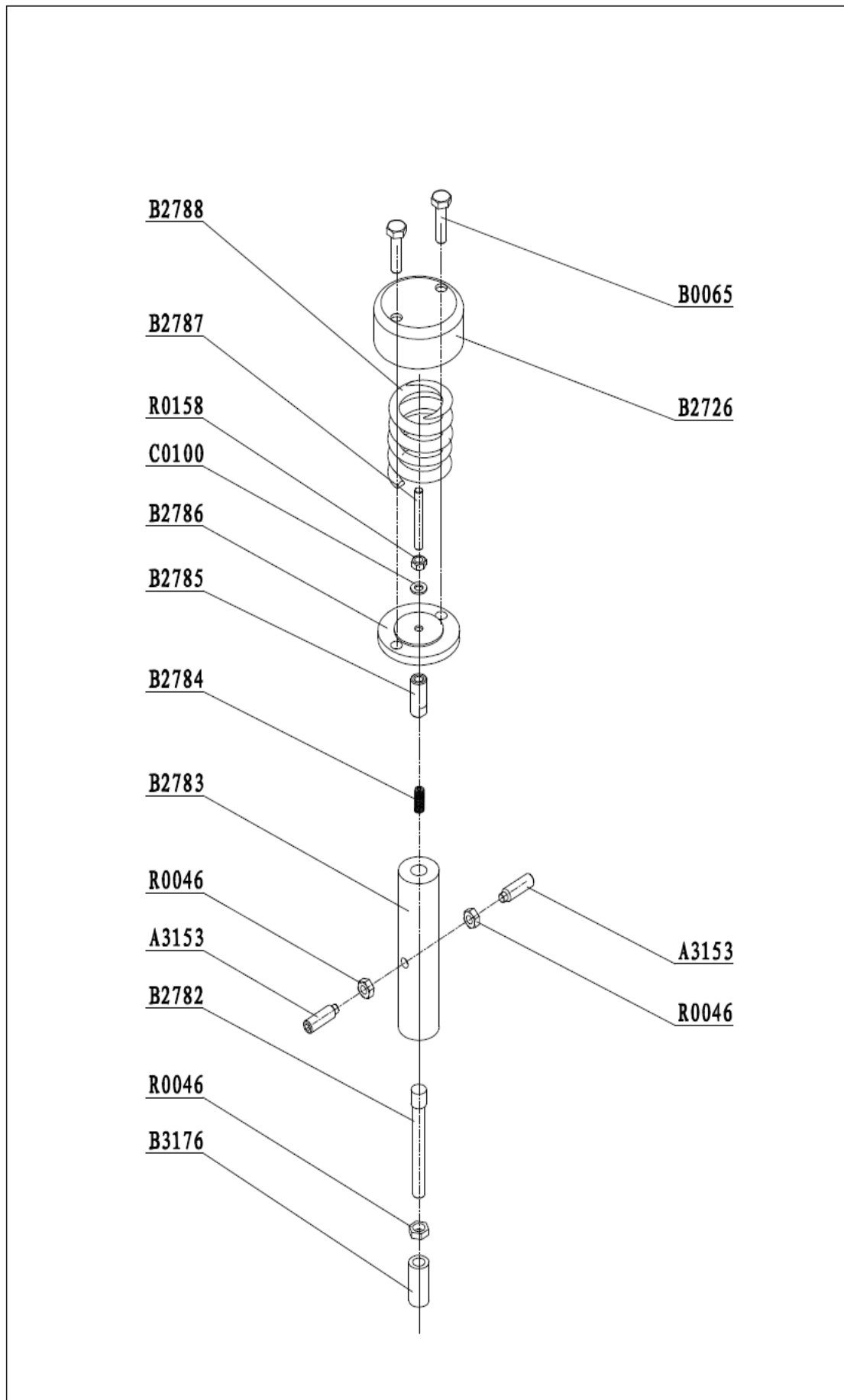

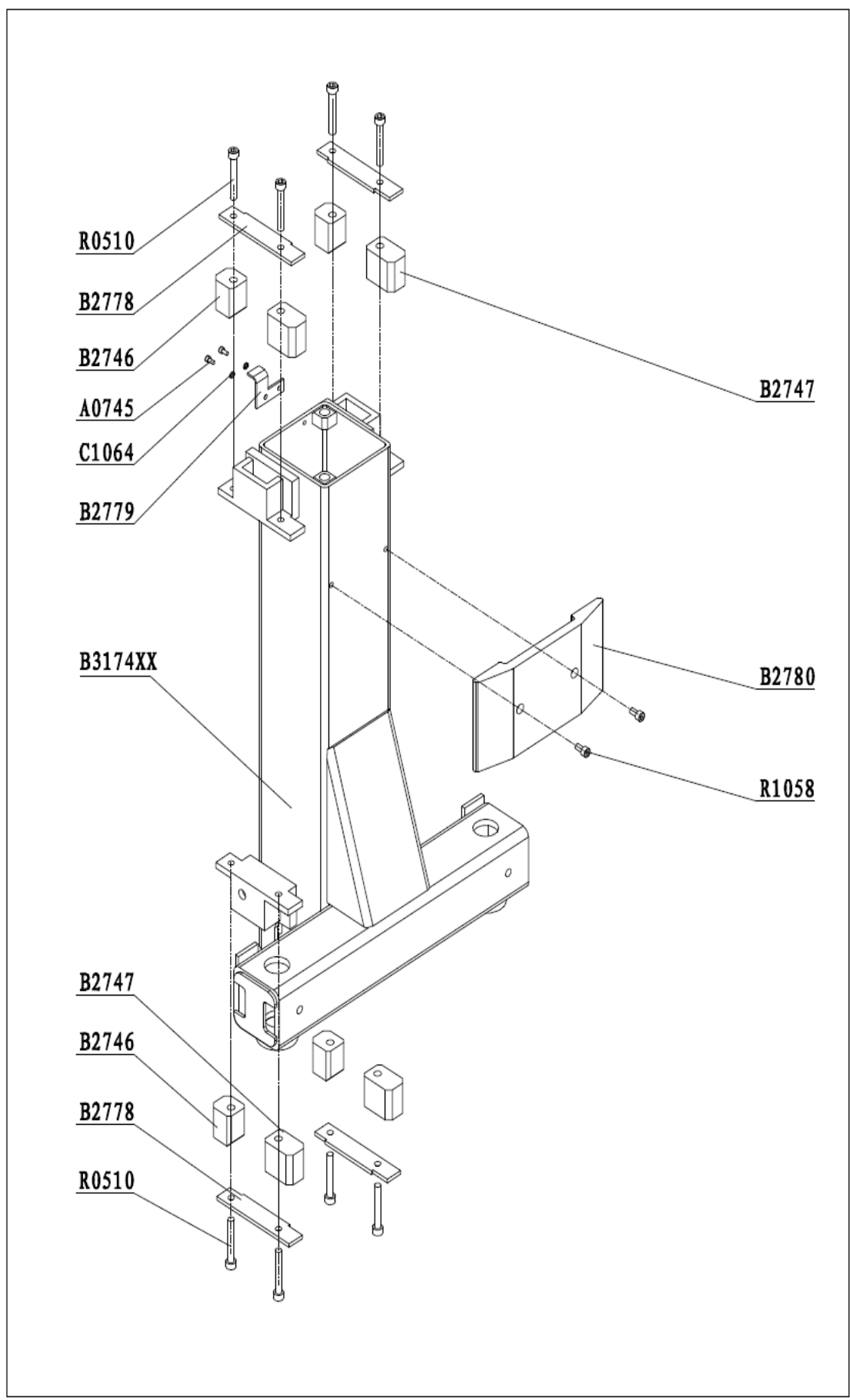

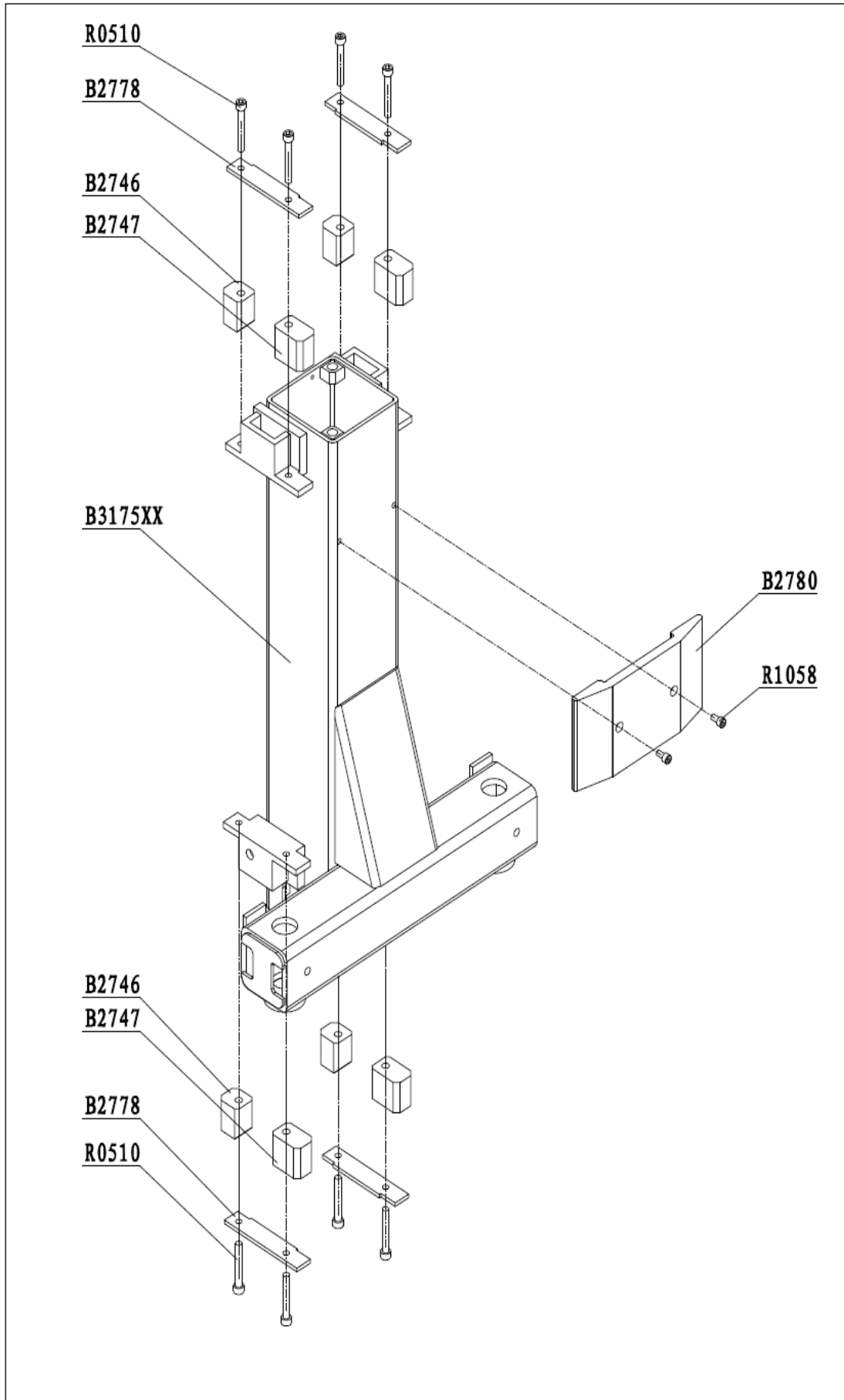

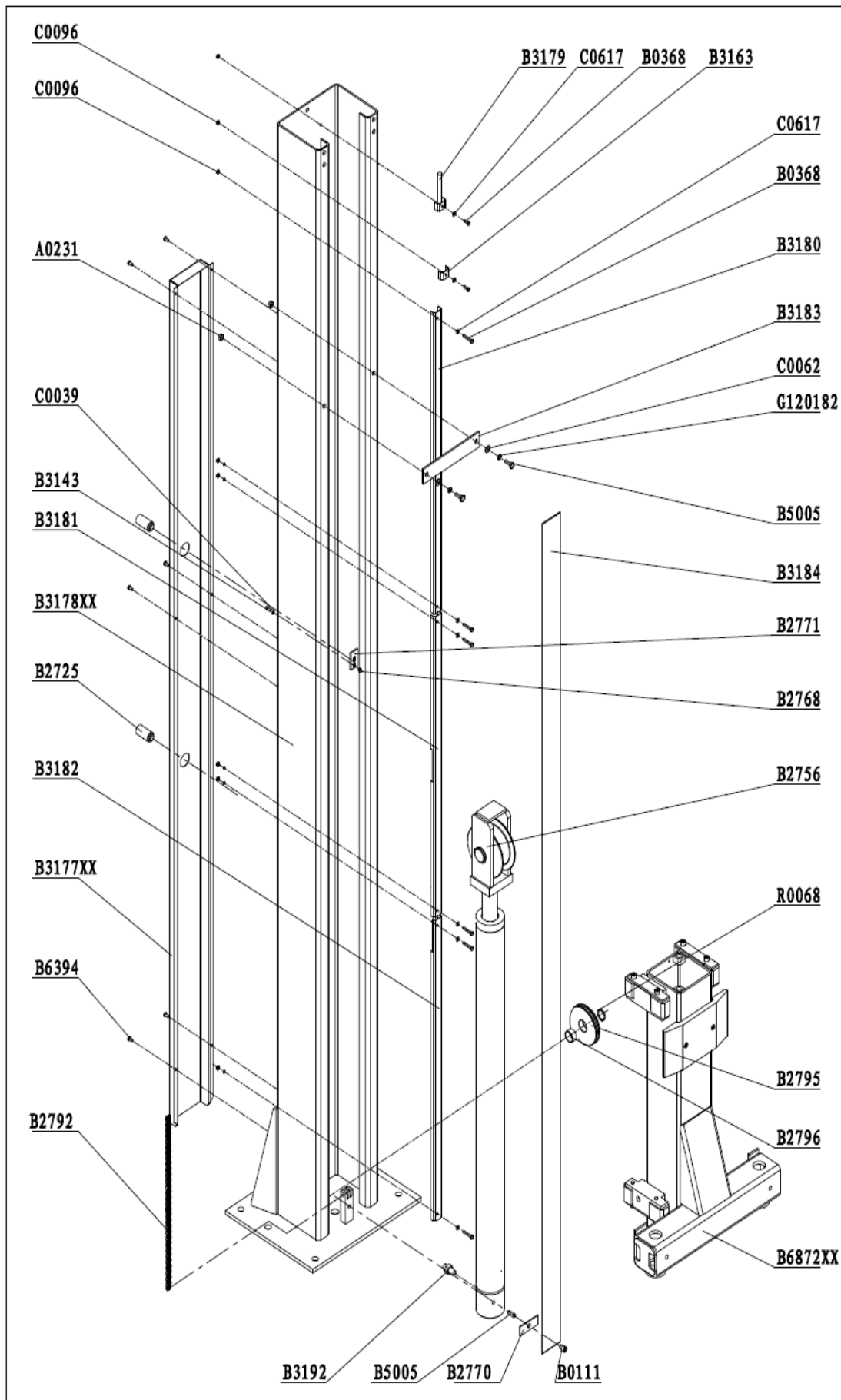

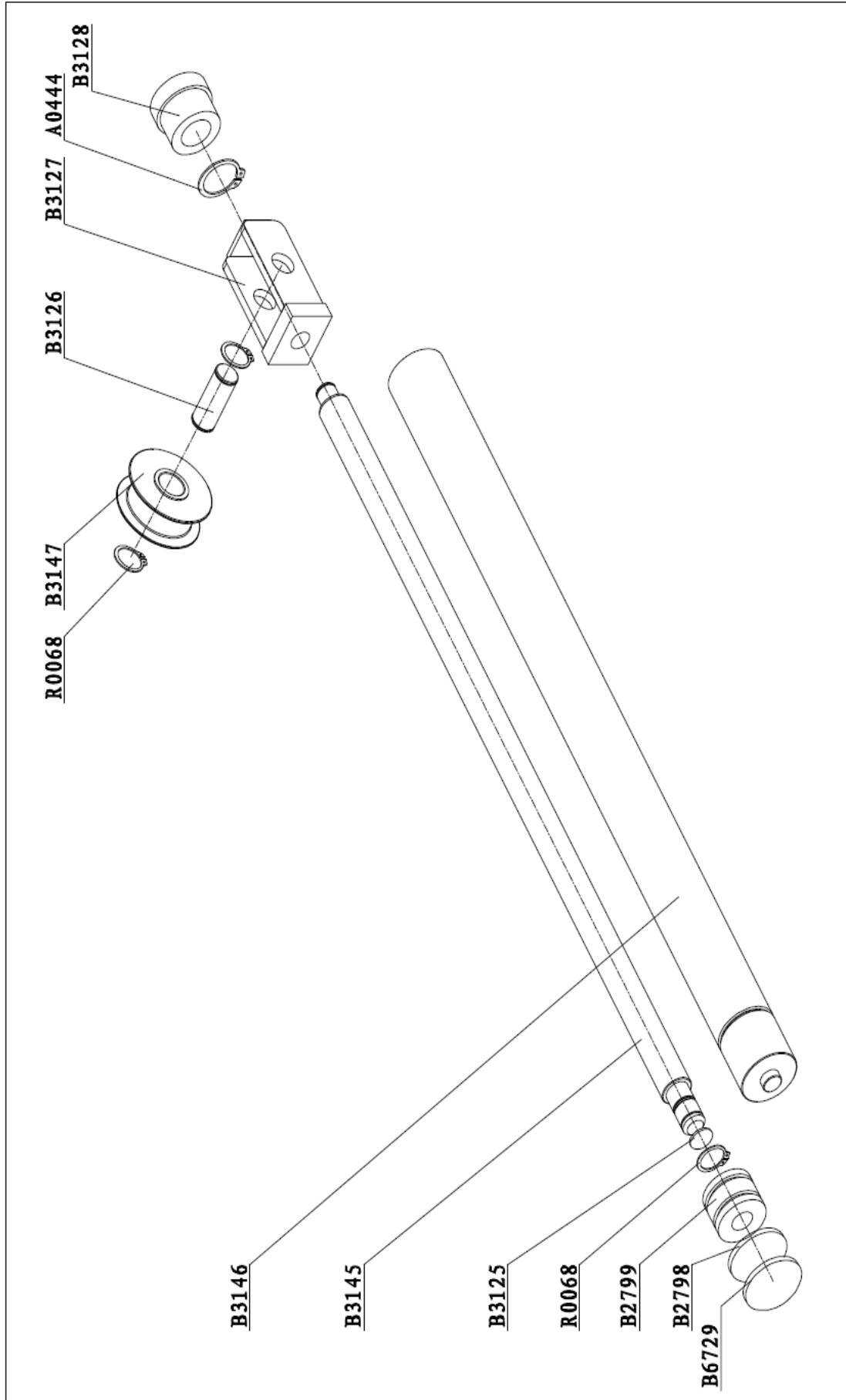

380V

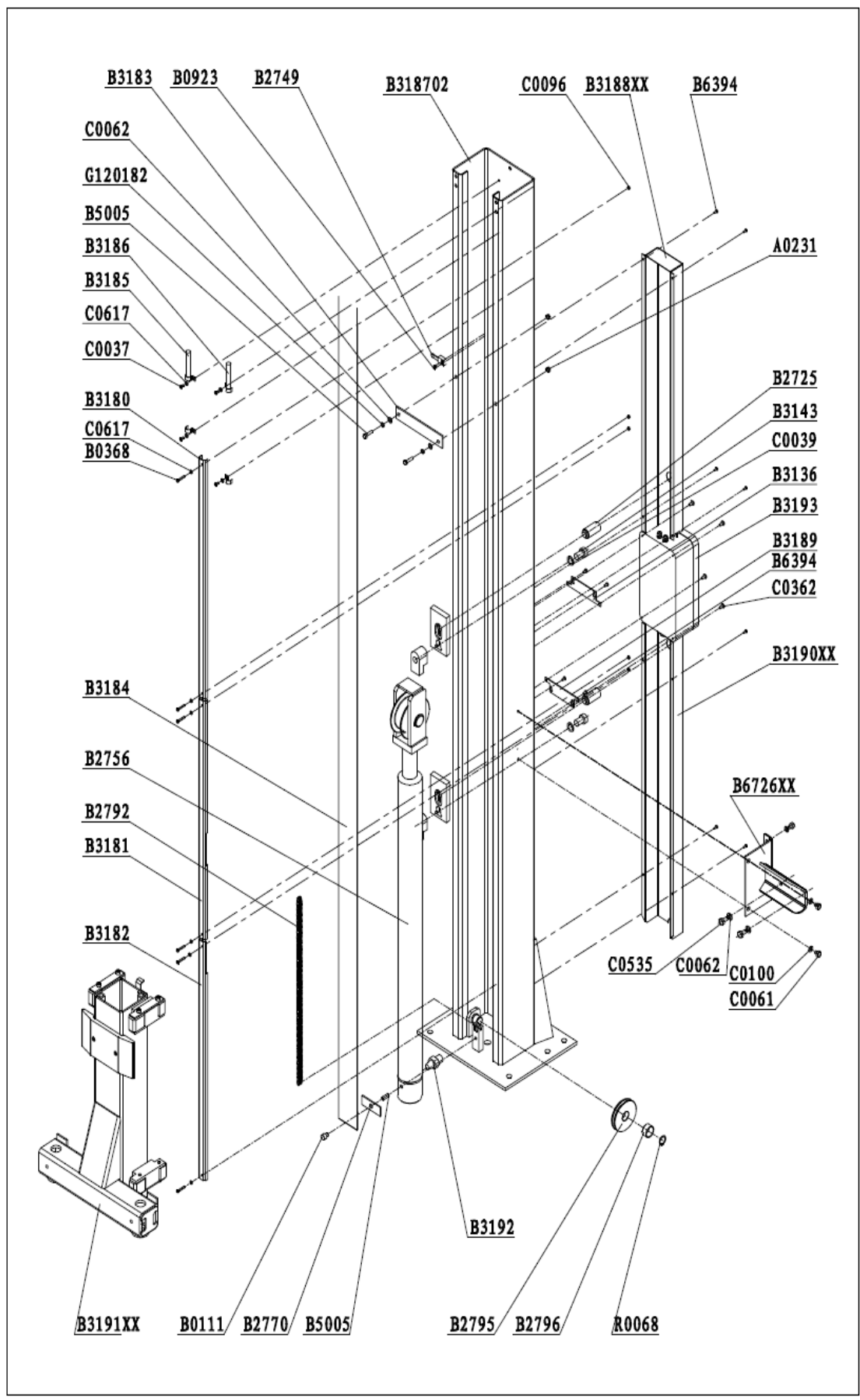

380V

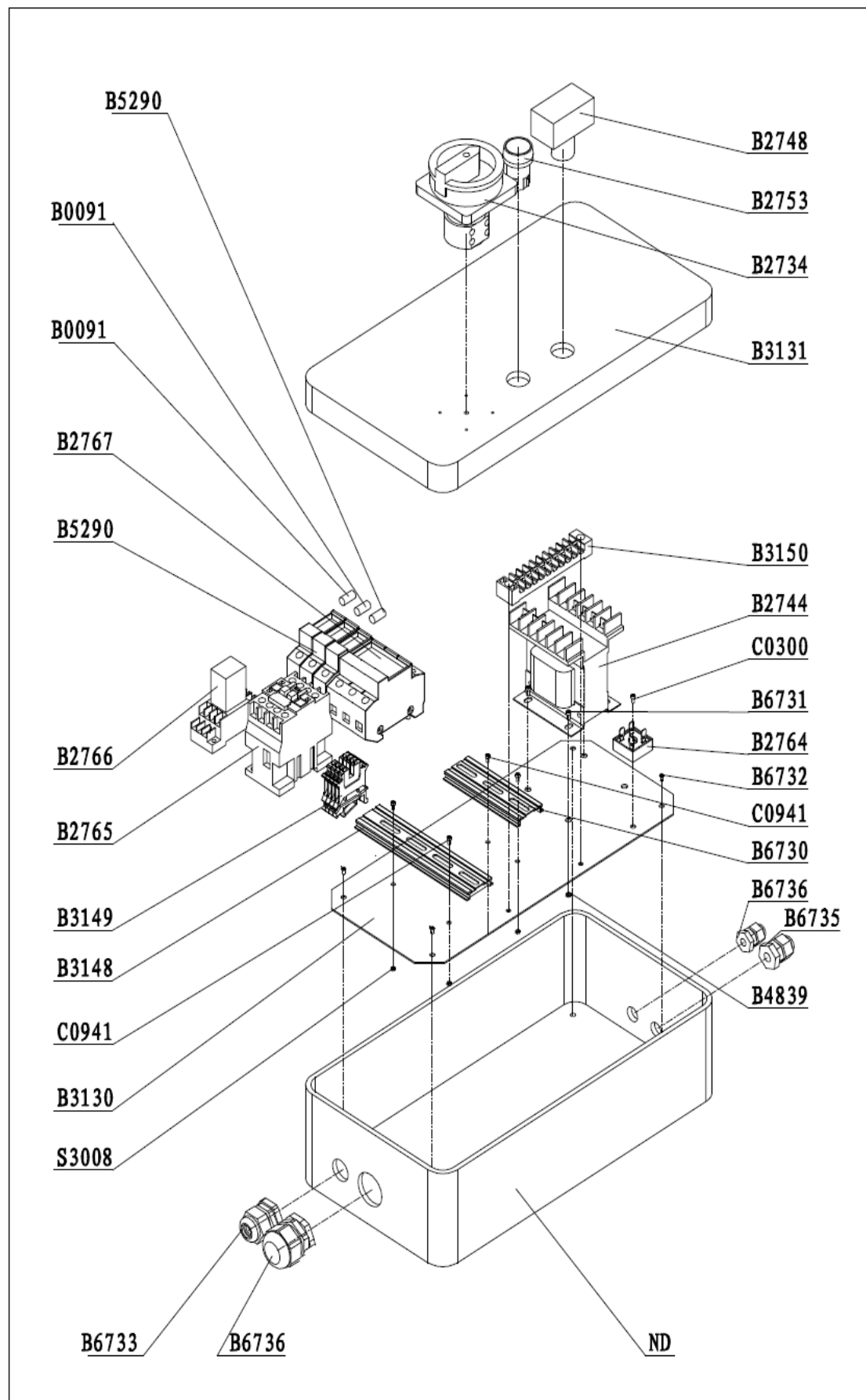

380V

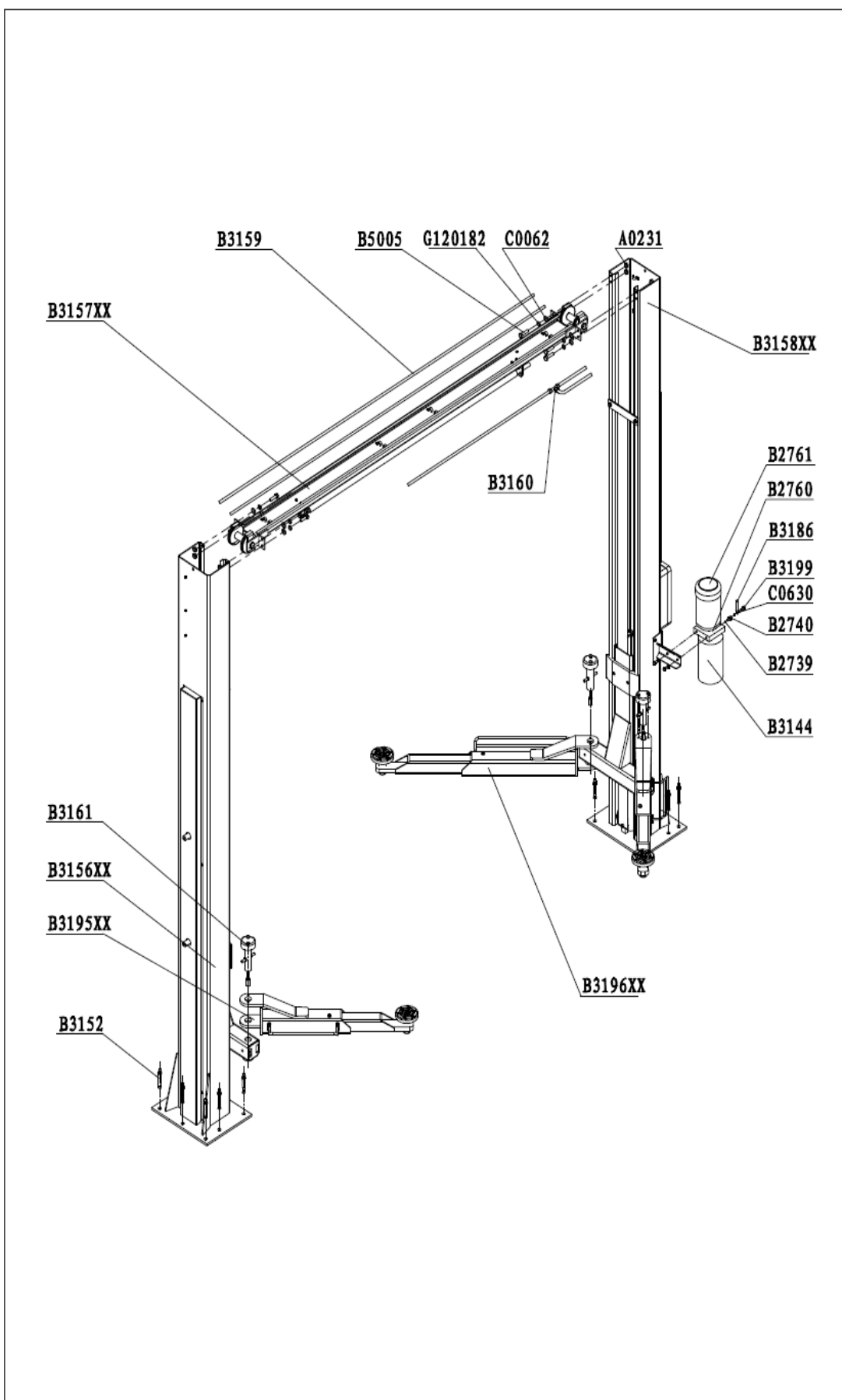

380V

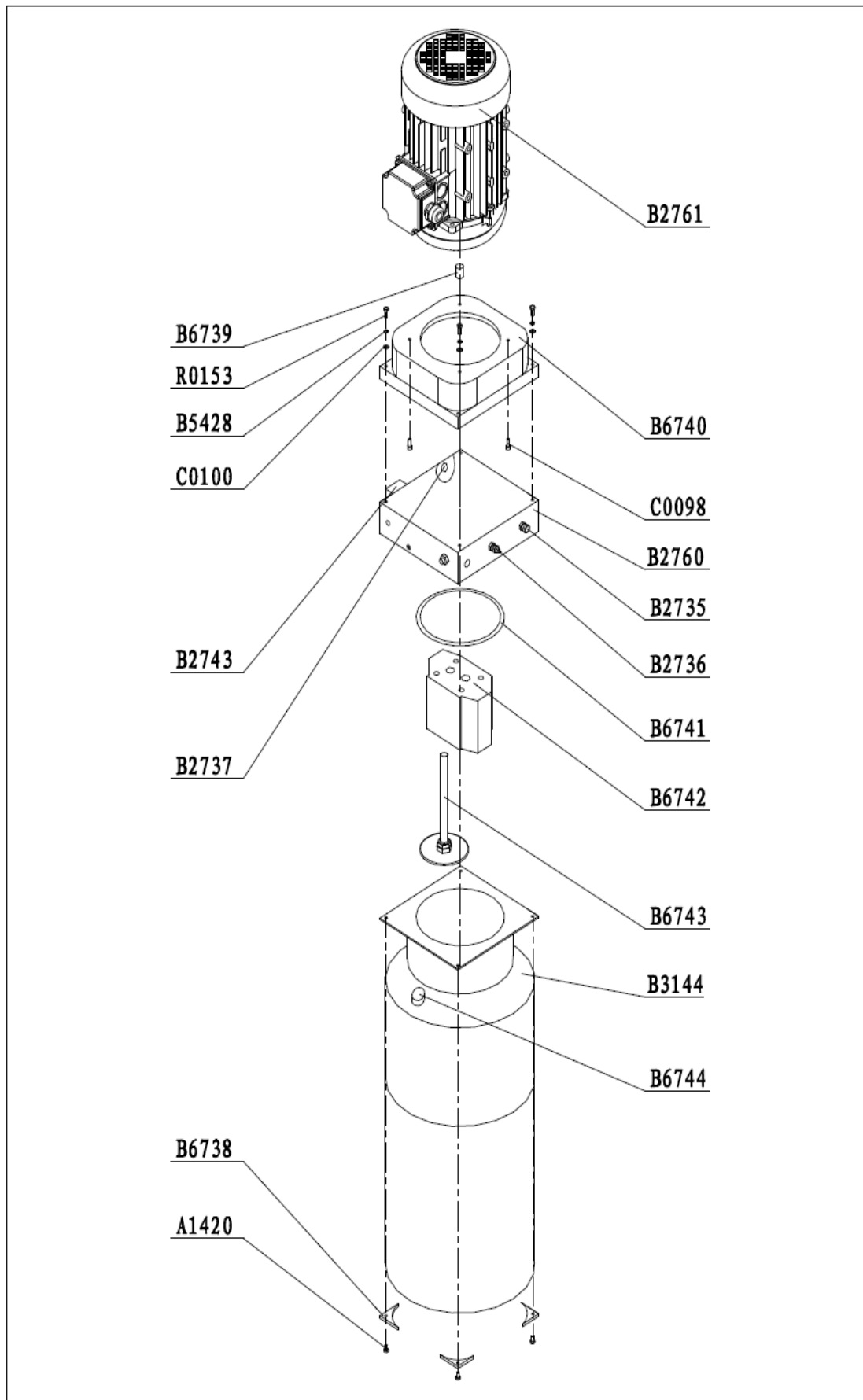

220V

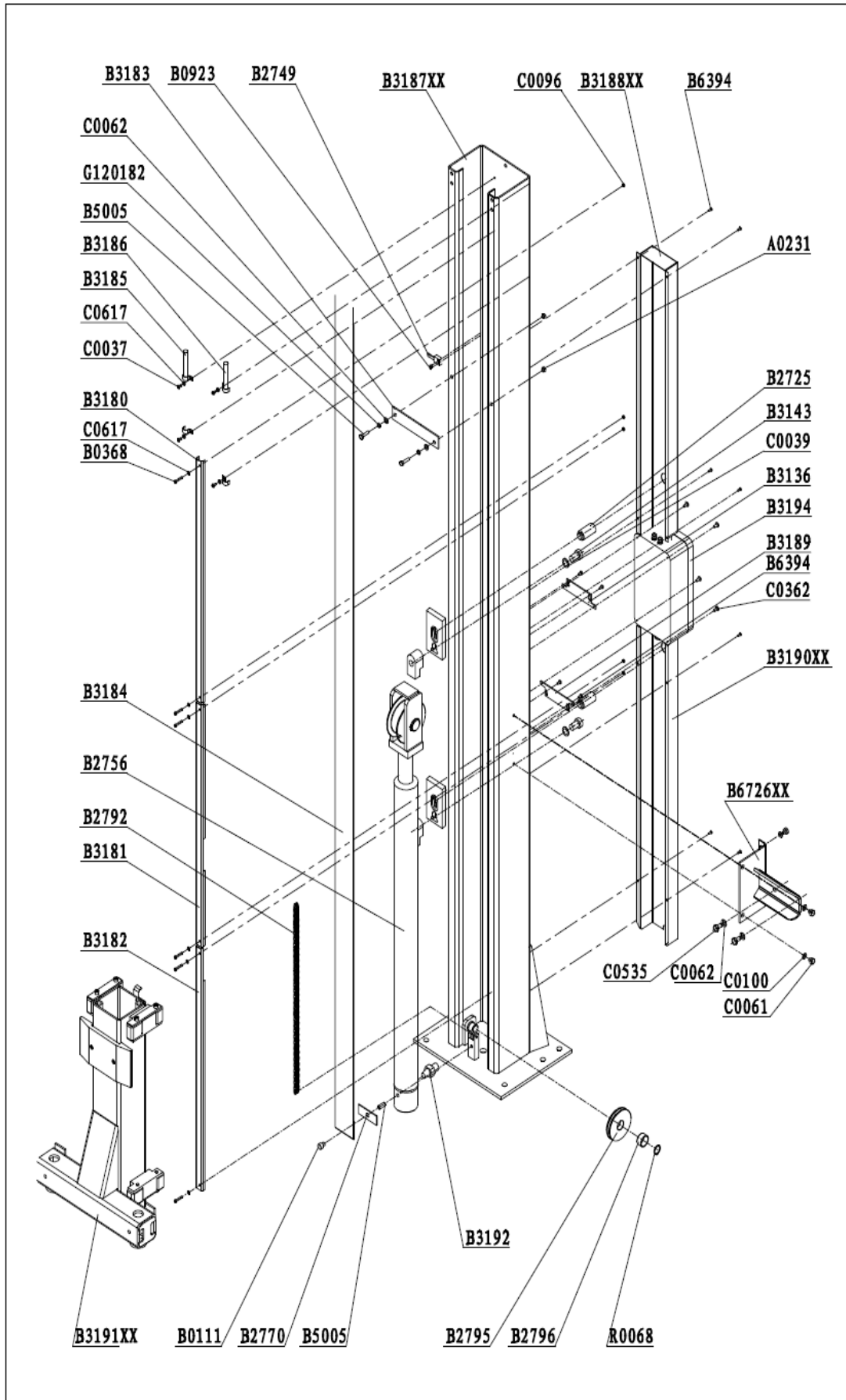

220V

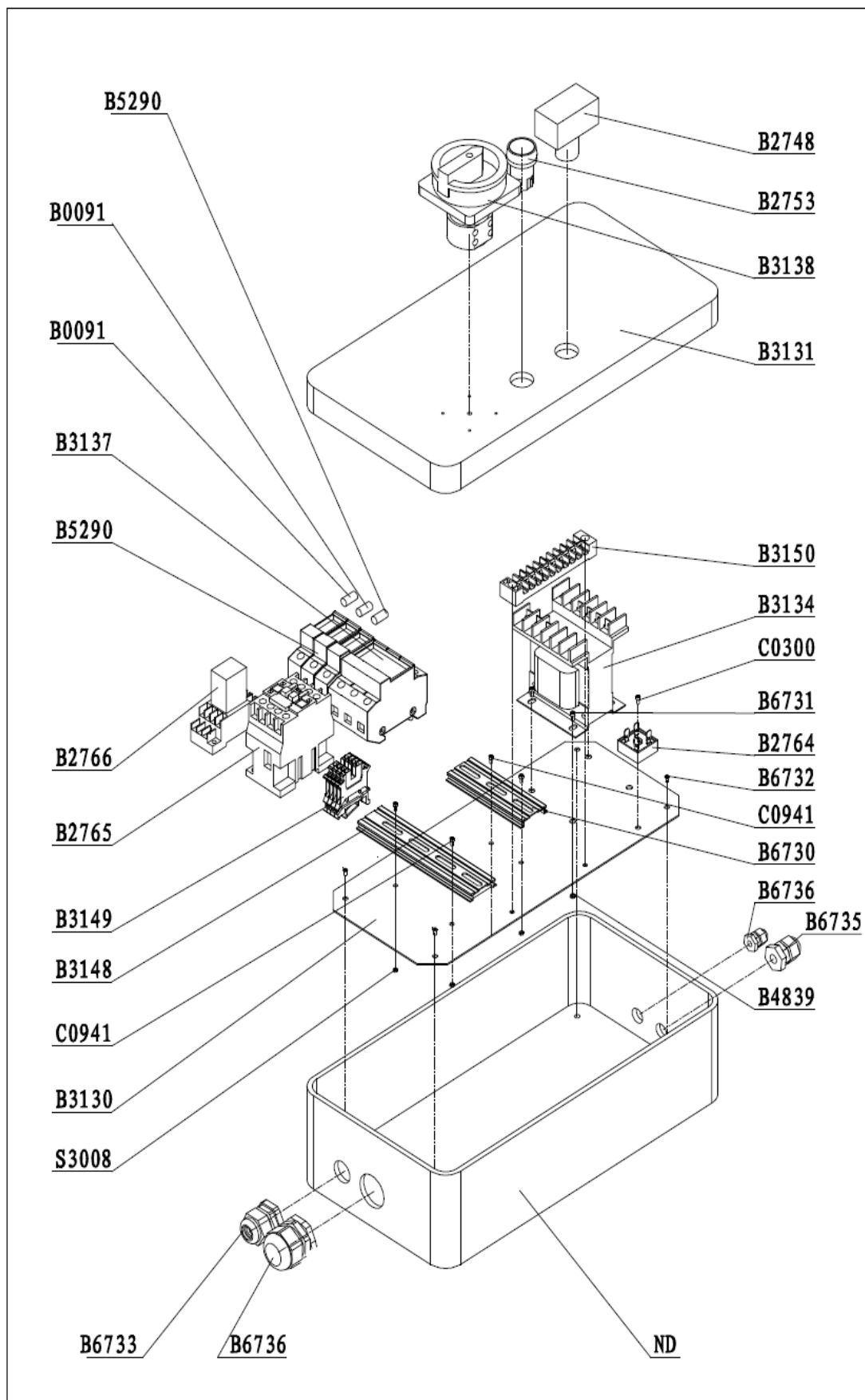

220V

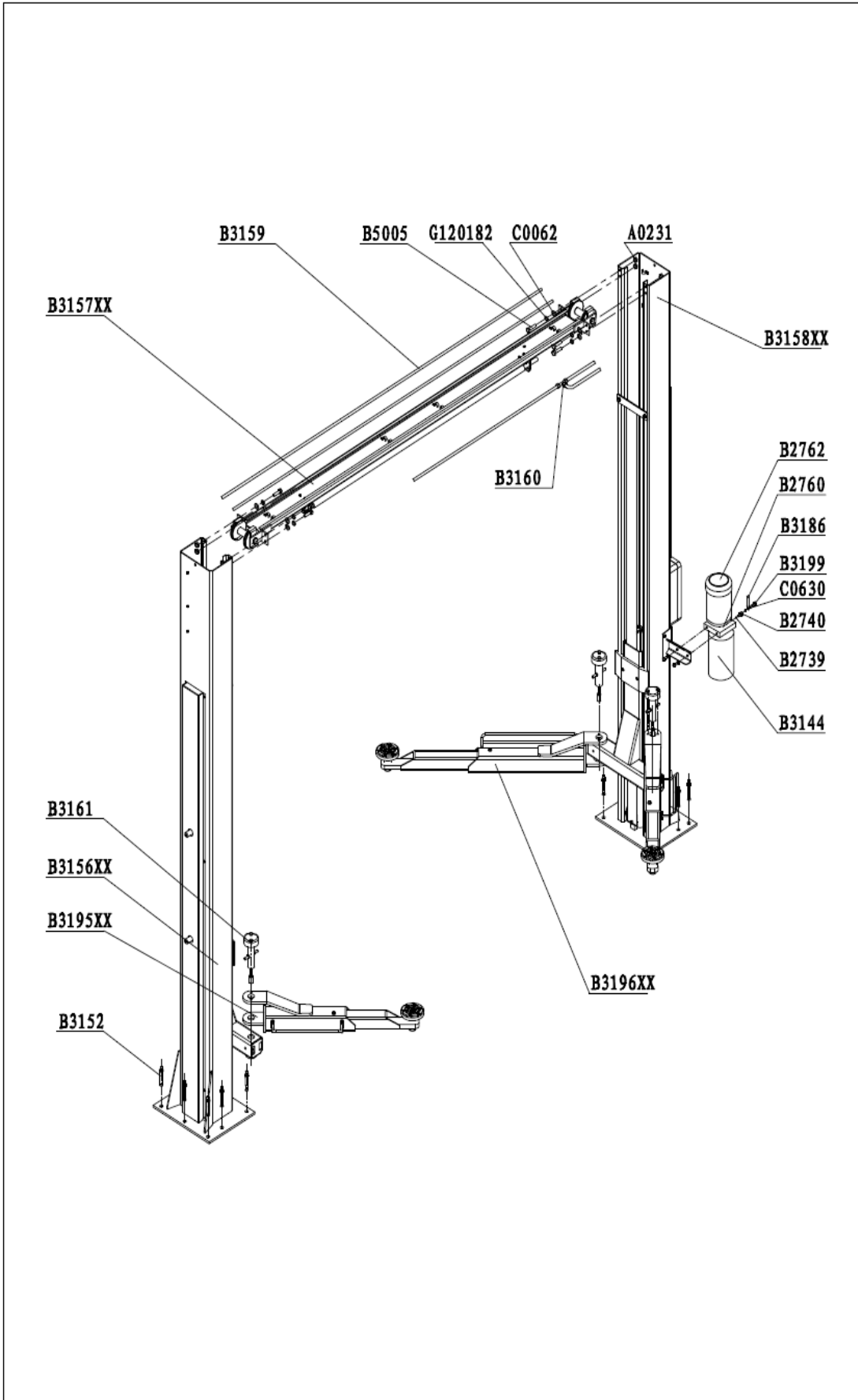

220V

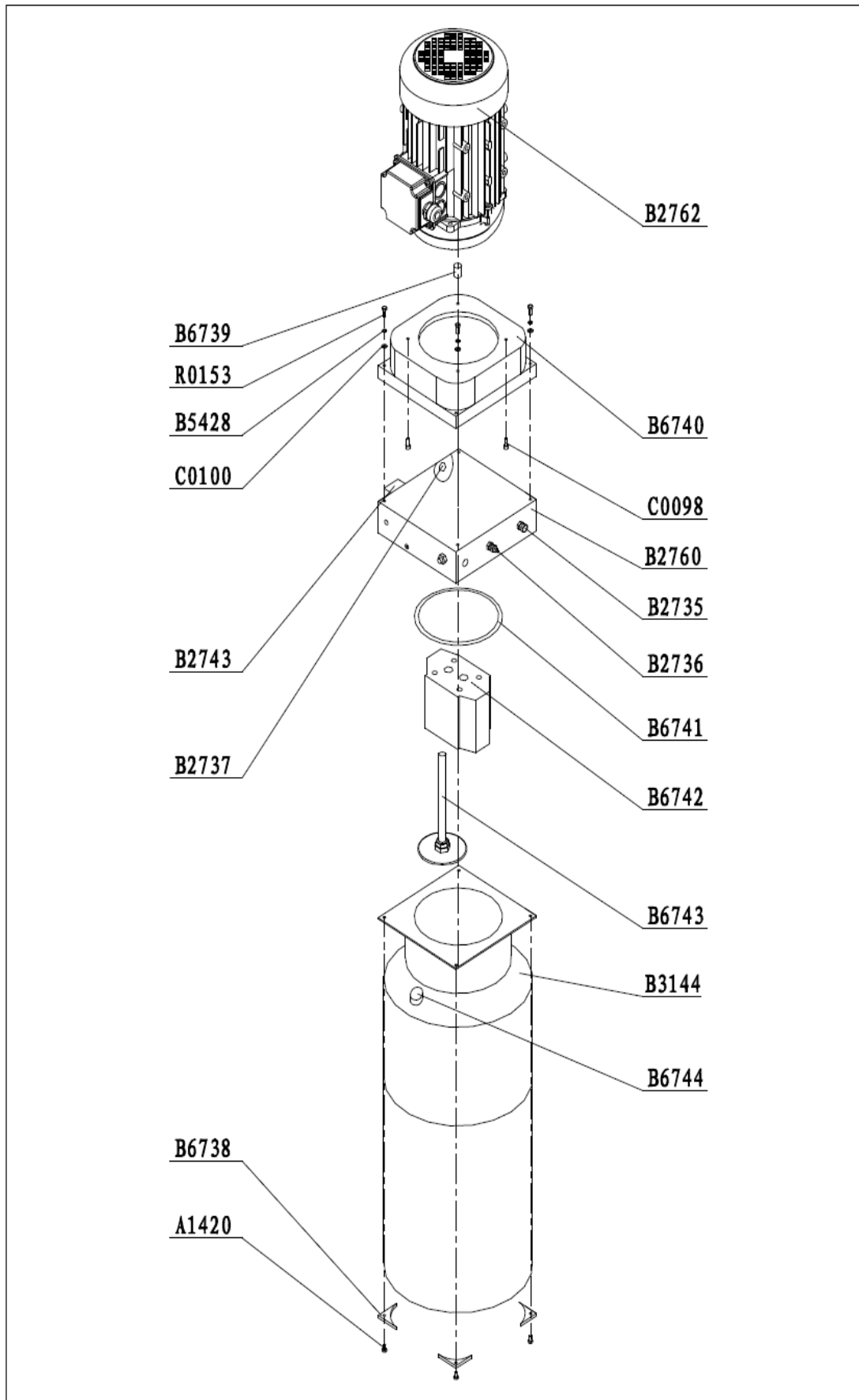

DB3000		SEAL RINGS IN CYLINDER	COMPLETE
DA3011Z		HIGH PRESSURE HOSE	COMPLETE
DB5000MZ		POWER UNIT	380V COMPLETE
DB5000MSZ		POWER UNIT	220V COMPLETE
B2749	*	LIMIT SWITCH	
B3162XX		CROSS BEAM	YSJ204W-010-00
B0368		BOLT	GB/T5781 M6X30
B3163		CLIP ORBIT	QJY3.2D-000-19
B3164		SLEEVE	YSJ3.5D-000-11
B3165		SHORT SLEEVE	YSJ204-000-06
B3166		BLOCKING BOARD	YSJ204-000-05
B3167		AXLE	YSJ3.5D-000-12
B0368		BOLT	GB/T5781 M8X40
B3168		INSTALLING BOARD	YSJ3.5D-000-01
C0099		BOLT	GB/T5781 M6X20
B3169		LONG AXLE SLEEVE	YSJ3.6-000-05
B0007		SCREW	GB/T889 M8
B3170		SAFETY BAR	YSJ3.5D-000-04
B3171		MOVABLE SEAT	YSJ3.5D-000-03
B3172		PROTECTION SLEEVE	YSJ3.5D-000-02
B3173		PROTECTION SLEEVE OF WIRE	QJY3.0-3000-03
B3174XX		MAIN CARRIAGE	YSJ204W-500-00
B6872XX		SUB CARRIAGE	YSJ204W-400-00
R0510		NUT	GB/T70.1 M10X70
B2778		PRESSING BOARD	
B2746		BACK BLOCK	

B2747		FRONT BLOCK	
B2779		LIMIT SWITCH BOARD	
C1064		SPRING WASHER	GB/T93 6
A0745		NUT	GB/T70.1 M6X12
B2780		PROTECTION BOARD	
R1058		NUT	GB/T70.1 M8X16
B2824		NUT	NUTM6X50
C0096		SCREW	GB/T6170 6
B2795		CABLE ROLLER	
B2796		COMPOSITE BUSH	3018
R0068		SHIELD RING	GB/T894.1 30
B2769		HANGING BOARD	
C0617		PLAIN WASHER	GB/T97.1 6
B0923		NUT	GB/T818 M4X30
B3176		ORIENTATION SLEEVE	YSJ204W-300-01
C0100		PLAIN WASHER	GB/T97.1 8
R0046		SCREW	GB/T6172 M12
B2782		LOCKING ROD	
A3153		TIGHTENING NUT	GB/T79 M12X40
R0046		SCREW	GB/T6170 M12
B2783		AXLE OF ARM LOCKING	
B2784		SPRING	
B2785		PIN AXLE	
B2786		LOCKING RING	
R0158		SCREW	GB/T6170 M8
B2787		DUAL-HEAD BOLT	M8X60

B2788		SPRING	
B0065		BOLT	GB/T27 M10X50
B2726		LOCKING COVER	
B0053		SHIELD RING	GB/T894.1 40
B6850XX		LONG SWING ARM	NEW TYPE
B0216		BOLT	GB/T5781 M8X12
B6711XX		LONG GUIDING RUNWAY	
B2789		LONG FEET GUARD	
B0121		BOLT	GB/T5781 M10X12
C0062		WASHER	GB/T848 10
B2763		RUBBER DISK	
B2790		BEARING	
B0600		SHIELD RING	GB895.2 26
B6715		SCREW SLEEVE	
B6717XX		SHORT SWING ARM	New Type
B6718		SHORT FEET GUARD	
B2791XX		SHORT GUIDING WAY	
B0053		SHIELD RING	GB/T895.2 40
B6719		SCREW SLEEVE	BIGGER
B6720		EXTENSION SUPPORT	150MM
ND		EXTENSION SUPPORT	80MM
B6721		SUPPORTING DISK	WITH 150MM SUPPORT
ND		SUPPORTING DISK	WITH 80MM SUPPORT
B0368		BOLT	GB/T5781 M6X30
B3163		CLIP ORBIT	QJY3.2D-000-19
B6872XX		SUB CARRIAGE	COMPLETE SET

B3177XX		COVER OF SUB COLUMN	YSJ204W-000-01
B3178XX		SUB COLUMN	YSJ204W-100-00
A0231		SCREW	GB/T6170 M10
B3179		HYDRAULIC HOSE	YSJ3.0-000-08
B6873		SCREW NAIL	GB/T818 M6X8
B3180		CLIP ORBIT	YSJ3.0-000-09
B3183		SEALING BOARD	YSJ3.5A-000-01
G120182		SPRING WASHER	GB/T93 10
B5005		BOLT	GB/T5781 M10X25
B3184		CANVUS	YSJ204W-000-04
B3185		HYDRAULIC HOSE	YSJ3.0-000-07
B3186		HYDRAULIC HOSE	YSJ3.0-000-06
B3187XX		MAIN COLUMN	YSJ204W-200-00
B3188XX		UPPER COVER OF MAIN COLUMN	YSJ204W-000-02
B3193		ELECTRICAL BOX	YSJ204W-100-00(THREE PHASE)
B6727		INSTALLING BOARD OF ELECTRICAL BOX	
B3190XX		DOWN COVER OF MAIN COLUMN	YSJ204W-000-03
B3191XX		MAIN CARRIAGE	COMPLETE SET
B3192		OIL JOINT	RT3.5-000-01
B3182		CLIP ORBIT	YSJ204W-000-06
B3181		CLIP ORBIT	YSJ204W-000-05
C0100		PLAIN WASHER	GB/T97.1 8
B2792		CHAIN	
B2725		SOLENOID	
C0535		BOLT	GB/T5781 M10X20

C0062		PLAIN WASHER	GB/T97.1 10
C0096		SCREW	GB/T6170 6
B2795		CABLE ROLLER	
B2796		COMPOSITE BUSH	3018
R0068		SHIELD RING	GB/T894.1 30
C0617		PLAIN WASHER	GB/T97.1 6
B3143		NUT	GB/T70.1 M5X16
B2771		LOCKING BOARD	
B2768		SELF LOCKING SCREW	
B2756		CYLINDER	COMPLETE SET
B0111		NUT	NUTM10X10
B2770		PRESSING BOARD OF CANVUS	
B5005		NUT	GB/T77 M10X25
B3136		INSTALLING BOARD OF ELETRICAL BOX	UPSIDE
B0923		NUT	GB/T818 M4X30
B2749	*	LIMIT SWITCH	
C0362		NUT	M4×10
C0061		BOLT	M8X10
B6726XX		INSTALLING BOARD OF PUMP	
B6727		INSTALLING BOARD OF ELETRICAL BOX	
B6394		SCREW NUT	GB/T 818 M6×8
B3156XX		SUB COLUMN	
B3157XX		CROSS BEAM	
B3158XX		MAIN COLUMN	
B3159		CABLE	
B3160		TRI-JOINT	GB/T5639.1 A8

A0231		SCREW	GB/T6170 M10
G120182		SPRING WASHER	GB/T93
B5005		BOLT	GB/T5781 M10X25
B3152		HOLD DOWN BOLT	COMPLETE SET
B3195XX		SHORT ARM	COMPLETE SET
B3196XX		LONG ARM	COMPLETE SET
B3161		ARM LOCKING SYSTEM	YSJ204W-300-00
B3199		SHORT PRESSING BOLT	
C0062		PLAIN WASHER	GB/T97.1 10
R0068		SHIELD RING	GB/T894.1 30
B2798	*	O-RING	GB/T3452.1 Φ 53X5.3
B2799		PISTON	
B3125	*	O-RING	GB/T3452.1 Φ 25X2.65
B3145		PISTON ROD	
B3146		CYLINDER	
B3147		CHAIN ROLLER	
B3126		AXLE OF CHAIN ROLLER	
B3127		CHAIN SEAT	
A0444		SHIELD RING	GB/T894.1 25
B3128		ORIENTATION SLEEVE	
B6729		Y-RING	D1 48
B2761		MOTOR	380V
B2762		MOTOR	220V
B3155		PRESSING BOLT	
C0630		COMPOSITE WASHER	
B2739		COPPER WASHER	

B2740		CONNECTING JOINT	
B3144		OIL TANK	
B3193	*	ELECTRICAL BOX 380V	COMPLETE SET
B0091		FUSE	2A
B5290		FUSE	6A
B3194		ELECTRICAL BOX 220V	COMPLETE SET
S3008		SCREW	M4
B3130		INSTALLING BOARD OF ELETRICAL ELEMENT	
C0941		NUT	M4X8
B3148		CLIP ORBIT	
B3149		WIRING TERMINAL	
B2765	*	AC CONTACTOR	
B2766	*	TIME RELAY	
B5290	*	FUSE SEAT	
B2767	*	CIRCUIT BREAKER	FOR THREE PHASE
B3137		CIRCUIT BREAKER	FOR SINGLE PHASE
B2748	*	BUTTON	
B2753	*	UNLOCKING BUTTON	
B2734	*	TRANSFORM SWITCH	380V
B313	*	TRANSFORM SWITCH	220V
ND	*	COVER OF ELECTRICAL BOX	YSJ204W-1100-01
B3150		WIRING TERMINAL	
B2744	*	TRANSFORMER	380V
B3134	*	TRANSFORMER	220V
C0300		NUT	GB/T65 M4X16
B6731		NUT	GB/T65 M5X8

B2764	*	RECTIFIER	
B6732		NUT	ST3.5X6.5
B6730		CLIP ORBIT	
B6733		WIRE TIGHTENING UNIT	PG7
ND		WIRE TIGHTENING UNIT	
B4839		SCREW	M5
ND		ELECTRICAL BOX	YSJ204W-1100-02
B6735		WIRE TIGHTENING UNIT	PG25
B6736		WIRE TIGHTENING UNIT	PG13.5
B2760		PUMP	WITHOUT MOTOR
B2761		MOTOR	380V
B2762		MOTOR	220V
B6738		TRIANGLE PLATE	
B2737		NON RETURN VALVE	
B2743		SOLENOID VALVE	
R0153		SCREW	GB/T 5781 M8X25
B6739		CONNECTING AXLE	
B6740		PUMP INSTALLING	
C0098		SCREW	GB/T 701 M8X20
B2735		OVERFLOWING VALVE	
B2736		ADJUSTING VALVE	
B6741		TIGHTENING RING	
B6742		GEAR PUMP	
B6743		FILTERING ROD	
B6744		BLOCKING CAP	