



**INSTRUCTION & MAINTENANCE MANUAL**

**TRUCK WHEEL BALANCER AUTO**

**Art. No. 9501006297**

## INDEX

1.	INTRODUCTION .....	1
2.	SPECIFICATION AND FEATURES .....	1
2.1	SPECIFICATION .....	1
2.2	FEATURES.....	1
2.3	WORKING ENVIRONMENT.....	1
3.	THE CONSTITUTION OF DYNAMIC BALANCER.....	1
3.1	MECHANIC PART .....	1
3.2	ELECTRIC SYSTEM .....	1
4.	INSTALLATION OF DYNAMIC BALANCER.....	2
4.1	OPENING AND CHECKING.....	2
4.2	INSTALLING MACHINE .....	2
4.3	INSTALLING HOOD .....	2
4.4	INSTALLING SCREW STUD OF DRIVE AXIS .....	2
5.	LED DISPLAY AND FUNCTION KEYS .....	3
5.1	LED DISPLAY AND KEY BOARD FUNCTION INTRODUCTION .....	3
5.2	COMBINATION FUNCTION KEYS INTRODUCTION .....	4
6.	INSTALLING AND DEMOUNTING THE WHEEL .....	4
6.1	CHECKING THE WHEEL.....	4
6.2	INSTALLING THE WHEEL.....	4
6.3	DEMOUNTING THE WHEEL .....	4
7.	THE INPUT METHODS OF RIM DATA AND THE WHEEL BALANCE OPERATION .....	4
7.1	THE POWER-ON STATE OF THE MACHINE .....	4
7.2	DATA OF WHEEL INPUT METHOD AND WHEEL BALANCE OPERATION FOR NORMALLY DYNAMIC BALANCE MODE.....	4
7.3	THE DATA INPUT METHOD OF ALU-1 MODE AND BALANCE OPERATION PROCESS .....	5
7.4	THE DATA INPUT METHOD OF ALU-2 BALANCE MODE AND WHEEL BALANCE OPERATION PROCESS.....	6
7.5	THE DATA INPUT METHOD OF ALU-3 BALANCE MODE AND WHEEL BALANCE OPERATION PROCESS.....	6
7.6	STATIC BALANCE (S) OPERATION PROCESS.....	6
7.7	RECALCULATION FUNCTION.....	7
8.	THE SELF-CALIBRATING OF DYNAMIC BALANCER.....	7
9.	GRAM-OZ CONVERSION OPERATION.....	8
10.	MACHINE SETTINGS .....	8
10.1	KEY-TONE FUNCTION SETTING .....	8
10.2	DISPLAY MONITOR BRIGHTNESS SETTINGS .....	8
10.3	INCH AND MM CONVERSION OPERATION .....	9
11.	MACHINE SELF TEST FUNCTION.....	9

11.1 LED AND INDICATING LIGHT CHECKING.....9

11.2 POSITION SENSOR SIGNAL CHECK .....9

11.3 PIEZOELECTRIC SENSOR SIGNAL CHECKING.....9

12. SAFETY PROTECTION AND TROUBLE SHOOTING .....9

    12.1 SAFETY PROTECTION .....9

    12.2 TROUBLE SHOOTING.....9

13.MAINTENANCE .....10

    13.1 THE DAILY MAINTENANCE BY NON – PROFESSIONALS ..... 10

    13.2 THE MAINTENANCE BY PROFESSIONALS ..... 11

14. POWER SUPPLY LAYOUT DIAGRAM..... 12

    14.1 220V LAYOUT DIAGRAM ..... 12

    14.2 380V LAYOUT DIAGRAM ..... 12

15. TROUBLE-ERROR CODE TABLE ..... 13

16. EXPLODED DRAWINGS ..... 14

17. SPARE PARTS LIST ..... 16

ACCESSORIES LIST ..... 17

## 1. Introduction

An imbalanced wheel will make the wheel jump and steering wheel wobble while driving. It can baffle the driver to drive, aggrandize the cleft of combine area of steering system, damage the vibration damper and steering parts, and increase the probability of the traffic accidents. A balanced wheel will avoid all these problems.

This equipment adopts the new LSI (Large Scale Integrated circuit) to constitute the hardware system that acquires processes and calculates information at a high speed.

Read the manual carefully before operating the equipment to ensure normal and safe operation. Dismantling or replacing the parts of equipment should be avoided. When it needs repairing, contact with technique service department. Before balancing, ensure the wheel fixed on the flange tightly. Operator should wear close-fitting smock to prevent from hanging up. Non-operator does not start the equipment.

No use while beyond the stated function range of manual.

## 2. Specification and Features

### 2.1 Specification

- Max wheel weight: 150kg/143lbs
- Motor power: 750W/550W
- Power supply: 222V(1/3PH) /380V(3PH)
- Rotating speed: 200r/min
- Cycle time: 8s
- Rim diameter: 13 " ~24 " (330mm~610mm)
- Rim width: 5.5 " ~20 " (140mm~510mm)
- Noise: <70dB
- Net weight: 226kg/498lbs
- Dimensions: 1220mm×960mm×1210mm

### 2.2 Features

- Adopt 6 LED display, it has flexible indicator operating function.
- Various balancing modes can carry out counterweights to stick, clamp and etc.
- Intelligent self-calibrating.
- Self fault diagnosis and protection function.
- Applicable for various rims of steel structure and duralumin structure.
- Balance car and truck tyres (maximum tyre diameter 1300mm), by pressing key "Z". Display panel has indicating lights to indicate tyre type. Car is for car tyre and Truck is for truck tyre.
- Equipped with pneumatic lifting device.
- Equipped with pedal braker for stable positioning and convenient adding weights

### 2.3 Working Environment

- Temperature: 5~50°C ;
- Altitude: ≤4000m
- Humidity: ≤85%

## 3. The Constitution of Dynamic Balancer

Two major components of the dynamic balancer are: mechanic part and electric system

### 3.1Mechanic part

The part consists of support, swing support and rotary main axis; they are together fixed on the frame.

### 3.2 Electric system

1. The microcomputer system consists of LED display, keyboard, and LSI circuit such as new MCU CPU.
2. Testing speed and positioning system consists of gear and opto-electronic coupler.
3. Two-phase asynchronous motor supplies and controlling circuit.
4. Horizontal and vertical pressure sensor.
5. Hood protection: machine can not start if protection hood is not put down.

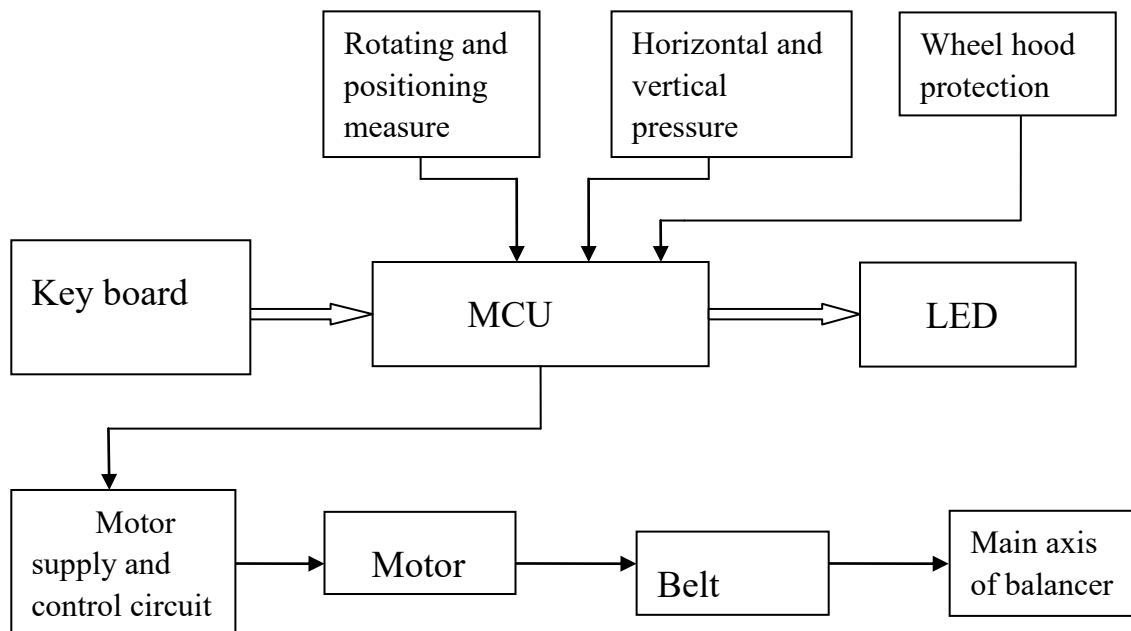

Figure 3-1 electric system

## 4. Installation of Dynamic Balancer

### 4.1 Opening and Checking

Open the package and check whether there are damaged parts. If there are any questions, please do not use the equipment and contact the supplier. Equipment standard accessories, please refer to the accessories table.

### 4.2 Installing machine

4.2.1 The balancer must be installed on the solid cement or similar ground. Unsolidified ground can bring measuring errors.

4.2.2 There should be 500mm around the balancer in order to operate conveniently.

4.2.3 Nail anchor bolts on the base's mounting hole of balancer to fix the balancer.

### 4.3 Installing hood

If protection hood needs to be installed, insert protection hood bracket to shaft on the back of machine body, and fix it with M16 screws in spare parts box.

### 4.4 Installing screw stud of drive axis

Fasten threaded screw as per following arrow direction (Figure 4-1).

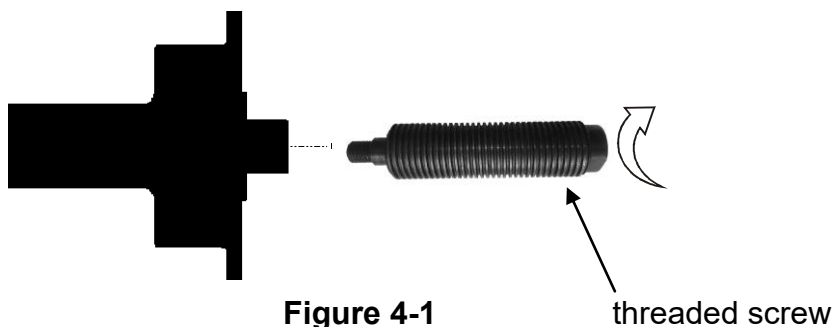
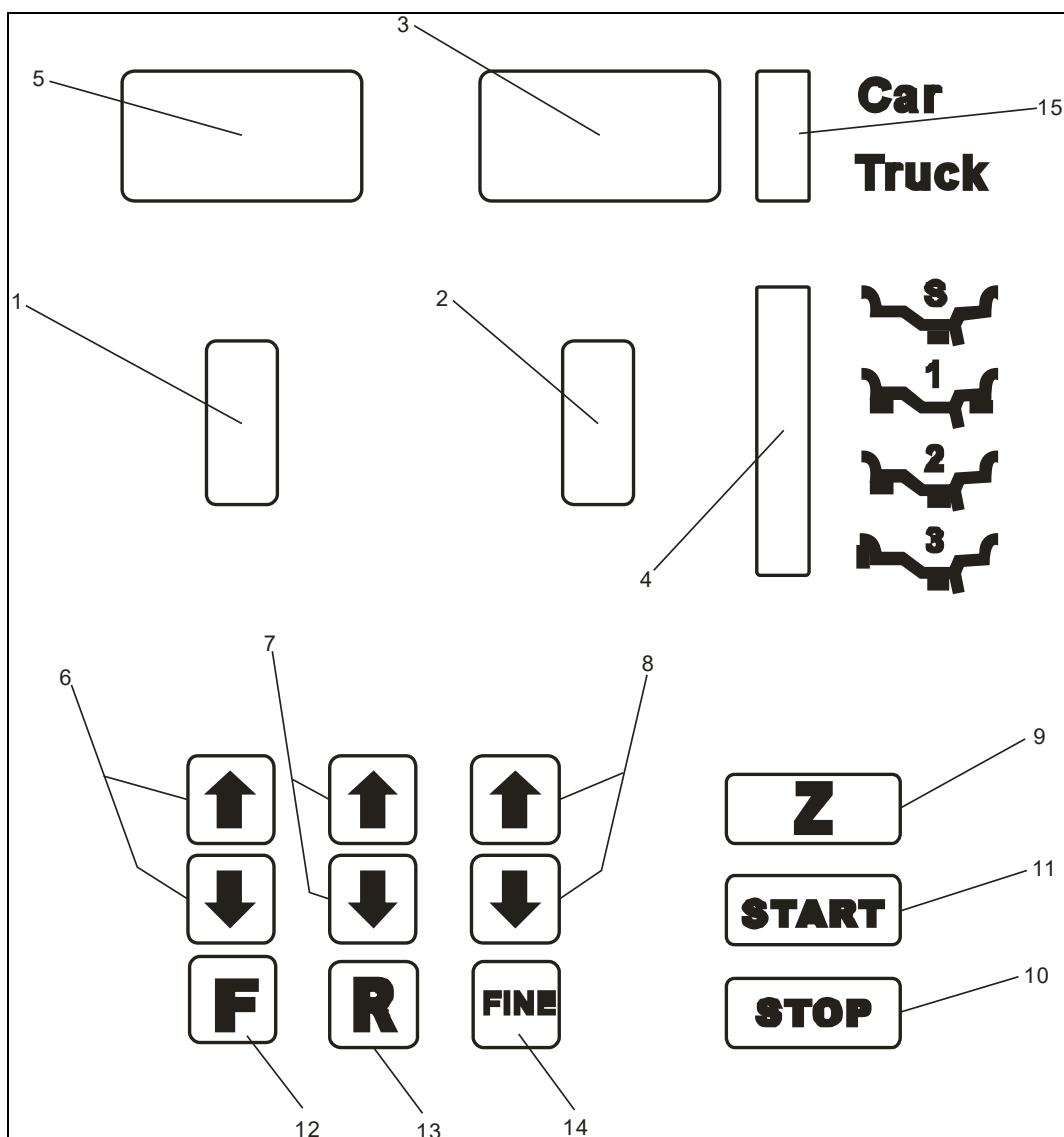

Figure 4-1

## 5. LED display and function keys

### 5.1 LED display and key board function introduction



**Figure 5-1**

- 1-Digital readout, position of imbalance, inside
- 2-Digital readout, position of imbalance, outside
- 3-Digital readout, amount of imbalance, outside
- 4-Indicator, "ALU" correction mode selected
- 5-Digital readout, amount of imbalance, inside
- 6-Push buttons, manual DISTANCE (a) setting
- 7-Push buttons, manual WIDTH (b) setting
- 8-Push buttons, manual DIAMETER (d) setting
- 9-Push button, car tyre and truck tyre shifting
- 10-Push button, emergency stop setting
- 11-Push button, machine start
- 12-Push button, balancing mode shifting
- 13-Push button, recalculate imbalance value or key for function combination
- 14-Push button, real imbalance amount displa

**NOTE:** Only use the fingers to press buttons. Never use the counterweight pincers or other pointed objects to press buttons.

## 5.2 Combination function keys introduction

[R] + [START]: Push buttons for self-calibration

[R] + [F]: Push buttons for self-checking

[STOP] + [a↓] + [a↑]: Push buttons for shift of gram and ounce

[STOP] + [F]: Push buttons for machine setting

## 6. Installing and Demounting the Wheel

### 6.1 Checking the wheel

The wheel must be clean, without sand or dust on it, and remove all the previous counterweights of the wheel. Check the tyre pressure whether up to the rated value. Check whether positioning plane of rim and mounting holes deformed.

### 6.2 Installing the wheel

6.2.1 Select the most suitable in the tire center hole of the cone;

6.2.2 Figure 6-1, install wheel and cone to main shaft, fasten handles and make sure cone can press wheel tightly. After fix wheel tightly, balancing operation can be carried out.

6.2.3 Figure 6-2, when balancing truck tyres, install a flange with diameter bigger than rim central hole size, to main shaft, then lift tyre by lifting device, install tyre to main shaft, put on a suitable cone and fasten tyre with quick release nut.

### 6.3 Demounting the Wheel

6.3.1 Demount the quick clamp

6.3.2 Raise the wheel and then take it down from main axis.



Figure 6-1



Figure 6-2

**Note: do not slide wheel on main shaft to prevent main shaft from scuffing while installation and demounting the Wheel**

## 7. The input methods of rim data and the wheel balance operation

### 7.1 The power-on state of the machine

After the machine is powered on, it starts initialization automatically. The initialization will be completed after two seconds. Then the machine enters normal dynamic (clamp counterweights on the correction plane of the both edged sides of rim) mode automatically (Figure 7-1), ready for input data of rim.

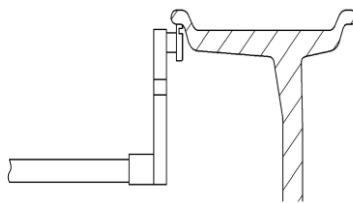

Figure 7-1

### 7.2 Data of wheel input method and wheel balance operation for normally dynamic balance mode

7.2.1 After the machine is powered on, it enters the normal balance mode

7.2.2 Input data of rim



**Figure 7-2**

Move the measure scale, pull the ruler head to the edge of the rim inside (Figure 7-2), and get the readout of value “a” indicated by ruler, then put ruler back. Press [a↓] or [a↑] to input value “a”.

7.2.3 Input data of rim width

Get the width value indicated on rim or measured by ruler, then press [b↓] or [b↑] key to input value “b”.

7.2.4 Input data of rim diameter.

Get the diameter value indicated on rim or measured by ruler, then press [d↓] or [d↑] key to input value “d”.

7.2.5 Normal dynamic balance mode operation process

Input data of rim, lay down protection hood, press START key to make wheel rotate. After stop, both sides LED displays show imbalance weight between both sides.

Slowly rotate wheel. When inside position indicator lights (figure 5-1(1)) are all on, clip corresponding counterweight, showing by left side LED displays, on 12 o'clock position on inside of rim ( figure 7-3 ). Again slowly rotate wheel. When outside position indicator lights (figure 5-1(2)) are all on, clip corresponding counterweight, showing by right side LED displays, on 12 o'clock position on the outside of rim (figure 7-4). Then lay down protection hood and press START key to make wheel rotate. After stop, both side LED displays show “0”. Balance process is completed.

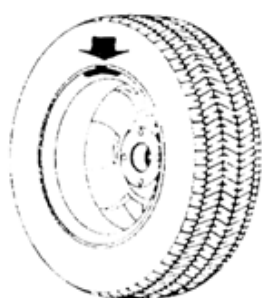

**Figure 7-3**

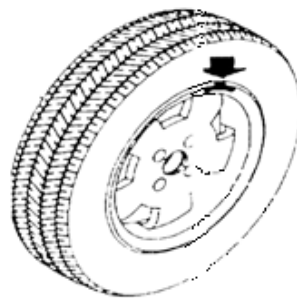

**Figure 7-4**

### 7.3 The data input method of ALU-1 mode and balance operation process

Follow 7.2 to input data of rim. Press F key to make ALU-1 indicating light on so as to balance wheel at ALU-1 mode.

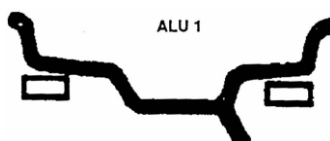

**Figure 7-5**

Input data of rim, lay down protection hood, press START key, rotate wheel. After stop, both sides LED displays show imbalance weight between both sides. Slowly rotate wheel. When inside position indicator lights (figure 5-1(1)) are all on, clip corresponding counterweight, showing by left side LED displays, on 12 o'clock position on inside of rim



( figure 7-5). Again slowly rotate wheel. When outside position indicator lights (figure 5-1(2)) are all on, clip corresponding counterweight, showing by right side LED displays, on 12 o'clock position on the outside of rim (figure 7-5). Then lay down protection hood and press START key to make wheel rotate. After stop, both side LED displays show "0". Balance process is completed

#### 7.4 The data input method of ALU-2 balance mode and wheel balance operation process

Follow 7.2 to input data of rim, press F key to make ALU-2 indicating light on. Then wheel can be balanced in ALU-2 mode.

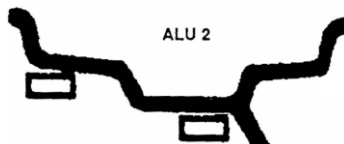

Figure 7-6

Input data of rim, lay down protection hood, press START key, rotate wheel. After stop, both sides LED displays show imbalance weight between both sides. Slowly rotate wheel. When inside position indicator lights (figure 5-1(1)) are all on, clip corresponding counterweight, showing by left side LED displays, on 12 o'clock position on inside of rim ( figure 7-6). Again slowly rotate wheel. When outside position indicator lights (figure 5-1(2)) are all on, clip corresponding counterweight, showing by right side LED displays, on 12 o'clock position on the outside of rim (figure 7-6). Then lay down protection hood and press START key to make wheel rotate. After stop, both side LED displays show "0". Balance process is completed

#### 7.5 The data input method of ALU-3 balance mode and wheel balance operation process

Follow 7.2 to input wheel data, press F key to make ALU-3 indicating light on, then wheel can be balanced in ALU-3 mode.

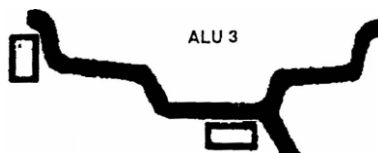

Figure 7-7

Slowly rotate wheel. When inside position indicator lights (figure 5-1(1)) are all on, clip corresponding counterweight, showing by left side LED displays, on 12 o'clock position on inside of rim ( figure 7-7 ). Again slowly rotate wheel. When outside position indicator lights (figure 5-1(2)) are all on, clip corresponding counterweight, showing by right side LED displays, on 12 o'clock position on the outside of rim (figure 7-7). Then lay down protection hood and press START key to make wheel rotate. After stop, both side LED displays show "0". Balance process is completed.

#### 7.6 Static balance (S) operation process

S mode is only suitable for rim, on which counterweight can be clipped on the middle position, such as motorcycle rim.

In the normal mode, measure diameter "d" of the position with counterweight (figure 7-10), then press [d+] or [d-] to input value "d". (Value "a" and value "b" can be random value). Press [F] to enter S mode.

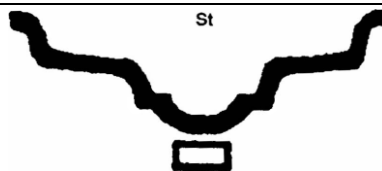

Figure 7-10

Input rim data, lay down protection hood, press START key to make wheel rotate. After stop, left side display shows ST, right side display shows imbalance amount (figure 7-11). Slowly rotate wheel. When inside position indicating lights (figure 5-1(1)) and outside position indicating lights (figure 5-1(2)) are all on, stick corresponding counterweight, showing LED displays, on 12 o'clock position on the rim (figure 7-10). Lay down protection hood, press START key to rotate the wheel. After stop, LED displays show "0". Balance process is completed.



Figure 7-11

### 7.7 Recalculation function

Before wheel balance testing, sometimes input of current data of rim is forgotten. You can input date of rim after wheel balance testing. No need to press START key. Only press recalculation key (R), system will follow new data of rim to calculate imbalance amount. Press R key against the interface currently showing imbalance value, currently rim data of input can be checked.

## 8. The Self-calibrating of Dynamic Balancer

The self-calibrating of dynamic balancer has been finished before ex-factory. But the system parameter may vary because of long-distance transportation or long-term use, which may cause error. Therefore, users can make self-calibrating after a period of time.

Process is as follows:

- 8.1 Power on machine. After the initialization ( figure 8-1), install a middle size and comparatively balanced wheel on which counterweight can be clipped. Then follow step 7.2 input data of rim;
- 8.2 Press R key and START key, (figure 8-1), lay down protection hood, press START key for next step, press STOP key to exit;



Figure 8-1

- 8.3 After main shaft stop (figure 8-2), open up protection hood, clip a piece of 100 gram counterweight on anywhere of outside of rim, lay down protection hood, press START key for next step, press STOP key to exit;



Figure 8-2

- 8.4 After main shaft stop (figure 8-3), Self-calibration is completed. Demount wheel, then balancer is ready to work.



Figure 8-3

**NB: In the process of self-calibration, data of rim for input must be correct. 100 gram counterweight must be accurate. Otherwise self-calibration result will be wrong. And wrong self-calibration will make balancer measure precision decline.**

## 9. Gram-Oz conversion operation

This operation for counterweight maund conversion (gram-Oz).

9.1 Press [STOP] key, [a↑] key and [a↓] key, display as per figure 9-1, denoting currently maund is gram;



Figure 9-1

9.2 Press [b↑] key or [b↓] key, display as per figure 9-2, denoting currently maund is Oz;



Figure 9-2

9.3 Press [b↑] key or [b↓] key again to shift maund between gram and Oz;

9.4 Press [a↑] key to save setup and exit. The setup is still remained after power off.

## 10. Machine settings

### 10.1 Key-tone function setting

This function can turn on or turn off key-tone. When function is turned on, system will make a sound “di” for every time key press. If the function is turned off, there will be no sound for key press.

Press STOP and F key (figure 10-1), Right side display shows ON, denoting function is on. Right side display shows OFF, denoting function off. Press [b↑] key or [b↓] key to shift between “ON” and “OFF”. Press [a↑] key to save settings and enter next step;



Figure 10-1

### 10.2 Display monitor brightness settings

This function will allow to set display brightness as per environment and user’s need;

Follow 10.1 to press [a↑] for enter setting (figure 10-2), Right side display shows brightness level. Totally there is 8 levels. Level 1 is dimmest and level 8 is brightest. Default level is 4. Press [b↑] key or [b↓] key to select brightness level. Press [a↑] key to save settings and enter next step;



Figure 10-2

### 10.3 INCH and MM conversion operation

Data on most rims is of INCH unit. If the unit is MM, length unit for system can be set to MM. Before unit setting, if the displayed value is fraction, current unit is INCH. If the displayed value is a whole number, current unit is MM. System default length unit is INCH. Setting of unit will not be maintained after power off.

Follow 10.2 to press [a↑] for entering setting (figure 10-3). Right side display shows ON, denoting unit is INCH. Right side display shows OFF, denoting unit is MM. Press [b↑] or [b↓] to shift setting between ON and OFF. Press [a↑] to save setting and exit;



Figure 10-3

## 11. Machine self test function

This function is for checking whether various input signals are ok or not, and provides gist for error analysis.

### 11.1 LED and indicating light checking

Press R key and F key, all the LEDs and indicating lights will flash in turn. This function is for checking fault LEDs or indicating lights. Press [STOP] key to exit. Then display figure 11-1 and enter position sensor checking. Press [SATOP] to exit

### 11.2 Position sensor signal check

This function is for checking whether position sensor, main shaft and main board circuit are ok or not.

As per figure 11-1, slowly rotate main shaft, the displayed value on the right side LEDs should change. Value increases for clockwise turn and decreases for anticlockwise turn. Normally the value changes from 0 to 63. Press [a↑] key, enter piezoelectric sensor checking. Press [STOP] key to exit.



Figure 11-1

### 11.3 Piezoelectric sensor signal checking

This function is for checking whether piezoelectric sensor, main board signal processing circuit and power are ok or not.

Follow 11.2 to press [a↑] key for entering (figure 11-2). Then gently press main shaft. Normally, the values on two sides LEDs will change. Press [a↑] key to exit.



Figure 11-2

## 12. Safety Protection and Trouble Shooting

### 12.1 Safety protection

Under the circumstance of operation, if the machine does not operate normally, Press STOP key, the rotating wheel will stop immediately, display OFF.

### 12.2 Trouble shooting

12.2.1 Press START key, main shaft not rotate, LED display shows Err-1-. Please check

- motor, power supply board, computer board and cable connections;
- 12.2.2 Press START key, main shaft rotate, LED display shows Err-1-. Please check position sensor, computer board and cable connections;
- 12.2.3 If main shaft still rotates for a long time without braking after balance test finish, please check brake resistance, power supply board, computer board and cable connections;
- 12.2.4 Power on machine and no display, please check whether power switch indicating light is flashing. If not, it is the power supply problem. Otherwise please check the power supply board, computer board and the cable connections;
- 12.2.5 Usually precision problem is not caused by the balancer machine. It is probably because of wrong wheel installation, or inaccurate counterweight, or inaccurate counterweight of 100 gram for balance self-calibration. Please reserve the original equipped 100 gram counterweight properly, which is for self-calibration only.
- 12.2.6 Instability and poor repeatability of data are not usually caused by the balancer machine. It is probably because of wrong wheel installation, or not firm or level-off ground. Please fix the machine by anchor bolts. Sometimes no connected earth wire may cause this phenomenon.
- 12.2.7 If add weights many times, the tire still can not be balanced, it is possible the operator did not find the correct unbalanced position and weights were not added on the correct position. Follow the instructions to do the self-calibration once. If still can not solve the problem, check it as following ways: 1)put down the protective cover, start the machine to test the tire; 2)turn the tire slowly by hand, to find the lateral unbalanced position; 3)add a 100g weight on the lateral position of rim(12 o'clock position); start the machine to test the tire, turn the tire by hand slowly, to find the lateral unbalanced position; check if the position of 100g weight is on the position of 6 o'clock(the bottom position); If no, it means the parameters of the machine has changed, please contact the dealer or manufacturer to solve it.

**Hint: right method to check precision:**

**Input right date of wheel(a. b. d value),consult instruction do a self-calibration, press START process balance operation, note down date of first time, clip 100 gram counterweight on the outside edge of wheel(when outside indicator light all on is top zenith position),press START key again process balance operation, this date of outside display addition date of first time, should amount  $100\pm 2$ ,manually slowly turn the wheel, when light of outside all on, check 100 gram counterweight whether at 6 o'clock position, if not amount 100 gram or 100 gram counterweight not at 6 o'clock position, indicate balancer precision have problem, if amount is 100 gram, follow same method check inside, check inside whether amount is 100 gram and at 6 o'clock.**

## 13. Maintenance

### 13.1 The daily maintenance by non – professionals

Before the maintenance, please switch off the power-supply.

13.1.1 Adjust the tension of the belt.

13.1.1.1 Dismantle the top cover hood;

13.1.1.2 Unscrew motor screw, move the motor till the belt's tension is proper,

and emphatically press the belt downwards about 4mm;

13.1.1.3 Screw motor screw and install the top cover hood.

13.1.2 Check whether the wires of electricity part connects are reliable.

13.1.3 Check whether the screw stud of the main shaft is loose.

13.1.3.1 Locking nut can not fix wheel tighten on main shaft.

13.1.3.2 Use hexagonal wrench to tighten the screw stud of the main shaft.

### 13.2 The maintenance by professionals

The professionals should be from the machine suppliers.

13.2.1 If the imbalance amount of tested wheel has obvious error ( amount is too big ) and can be improved after self-calibrating, it proves the parameter in the machine has changed and needs professionals to correct it.

13.2.2 The replacing and adjusting for pressure sensor should be operated by professionals as per the following methods:

1. Unscrew the No.1, 2,3,4,5 nuts.

2. Dismantle the sensor and screw stud.

3. Replace No.6, 7 the sensor components.

4. Install the sensor and the screw stud as per Figure 12-1. (Pay attention to the sensor's direction.)

5. Screw No.1 nut emphatically.

6. Screw the No.2 nut to make the main shaft and the flank of cabinet vertical, and then emphatically screw the No.3 nut.

7. Screw the No.4 nut (not so emphatically), then screw No.5 nut.

13.2.3 The replacing of circuit board and its components should be operated by professionals.

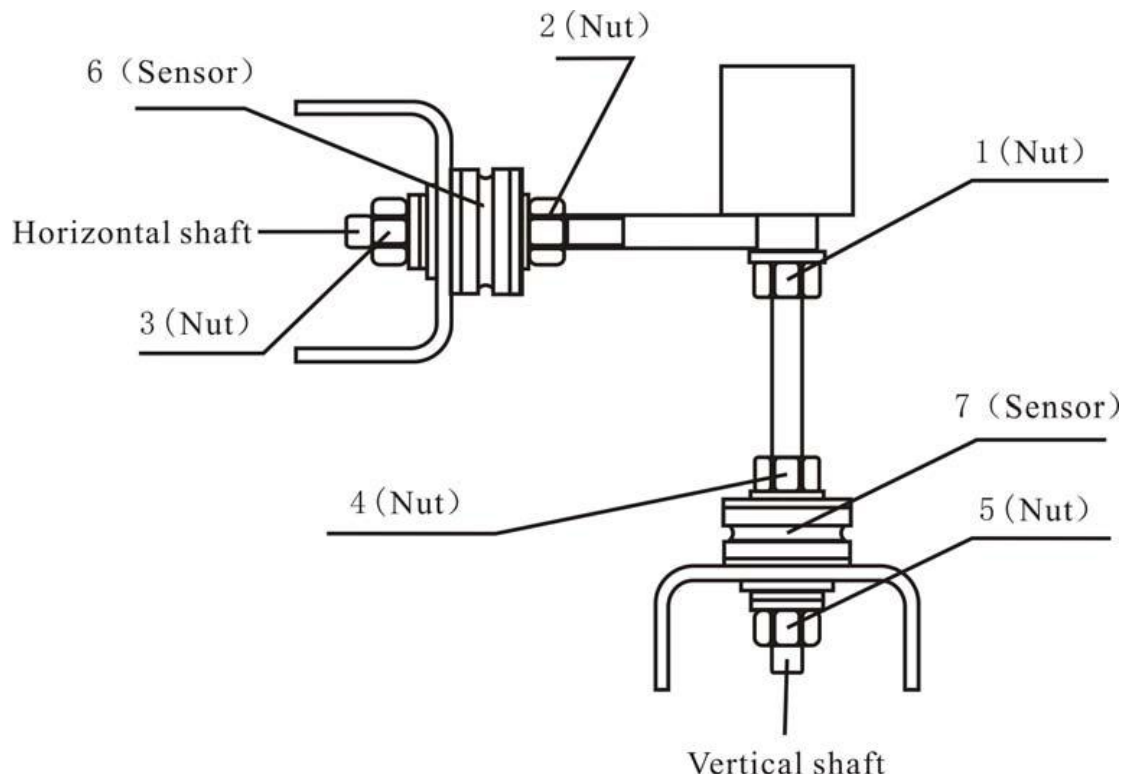
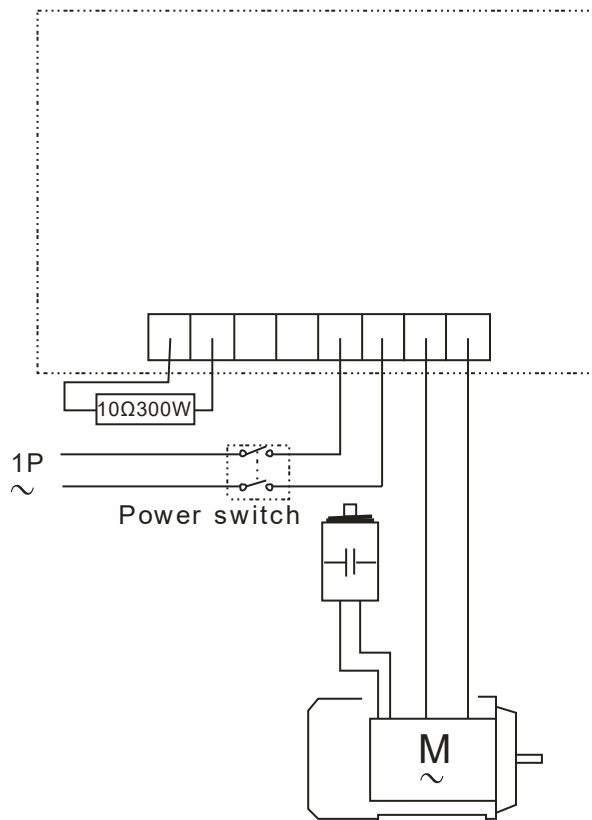

Figure 18-1

## 14. Power supply layout diagram

### 14.1 220V layout diagram



### 14.2 380V layout diagram

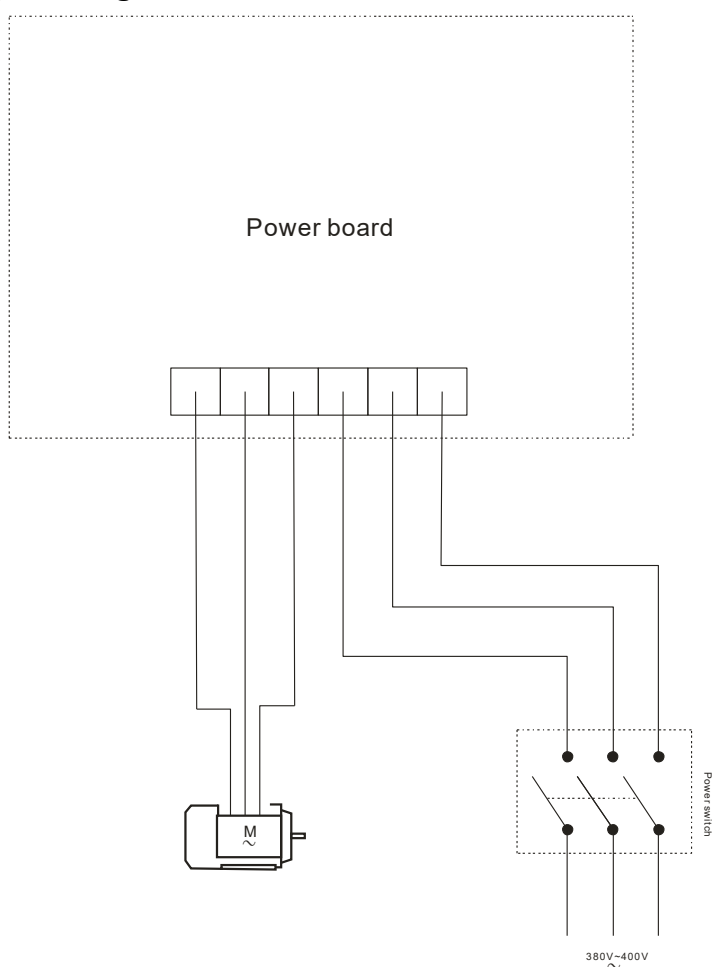

### 15. Trouble-error code table

When balancer displays hint of error, please refer to below table to shoot troubles:

Code	meanings	cause	remedy
Err 1	Main shaft not rotate or have no rotate signal	1.motor fault 2.position sensor fault 3.power supply board fault 4.computer board fault 5.connection-peg untouched	1.change motor 2.change position sensor 3.change power supply board 4.change computer board 5.check cable connections
Err 2	The rotation speed low	1. position sensor fault 2. wheel not installed tightly or wheel too light 3. motor fault 4. driving belt too loose or too tight 5. computer board fault	1. change position sensor 2. re-install wheel tightly 3. change motor 4.adjust driving belt elasticity 5. change computer board
Err 3	Miscalculation	imbalance amount beyond calculation range	Repeat self-calibration or change computer board
Err 4	Main shaft rotation backwards	1. position sensor fault 2. computer board fault	1. change position sensor 2. change computer board
Err 6	Sensor signal transact circuit not work	1. power supply board fault 2. computer board fault	1.change power supply board 2. change computer board
Err 7	Lose data of interior	1. self-calibration failure 2. computer board fault	1. Repeat the self-calibration 2. change computer board
Err 8	Self-calibration memory failure	1. not clip 100 gram on the rim when self-calibration 2. power supply board fault 3. computer board fault 4. press sensor fault 5. connection-peg untouched	1.follow right method to repeat self-calibration 2.change power supply board 3. change computer board 4.change press sensor 5.check cable connection



16. Exploded drawings

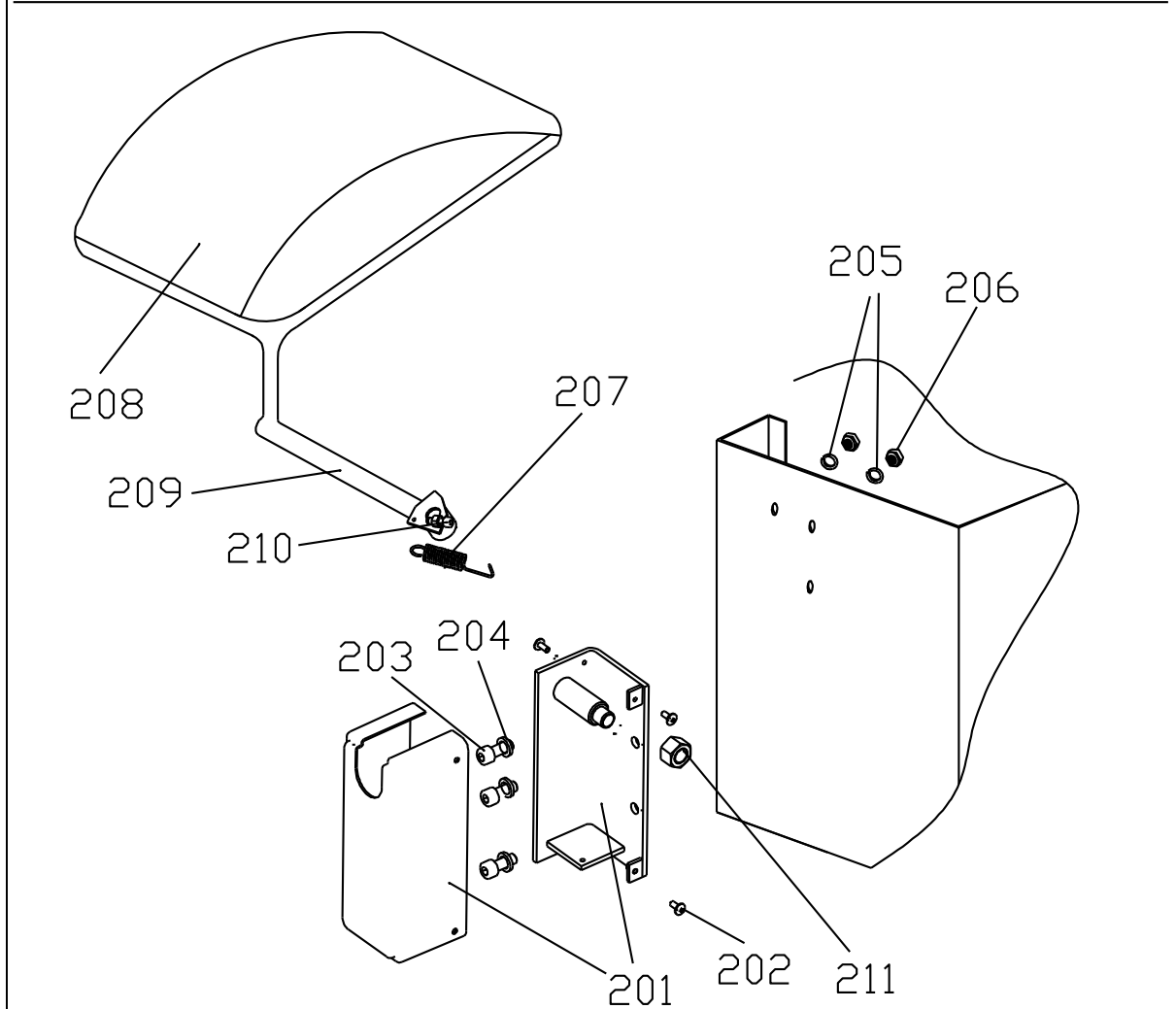
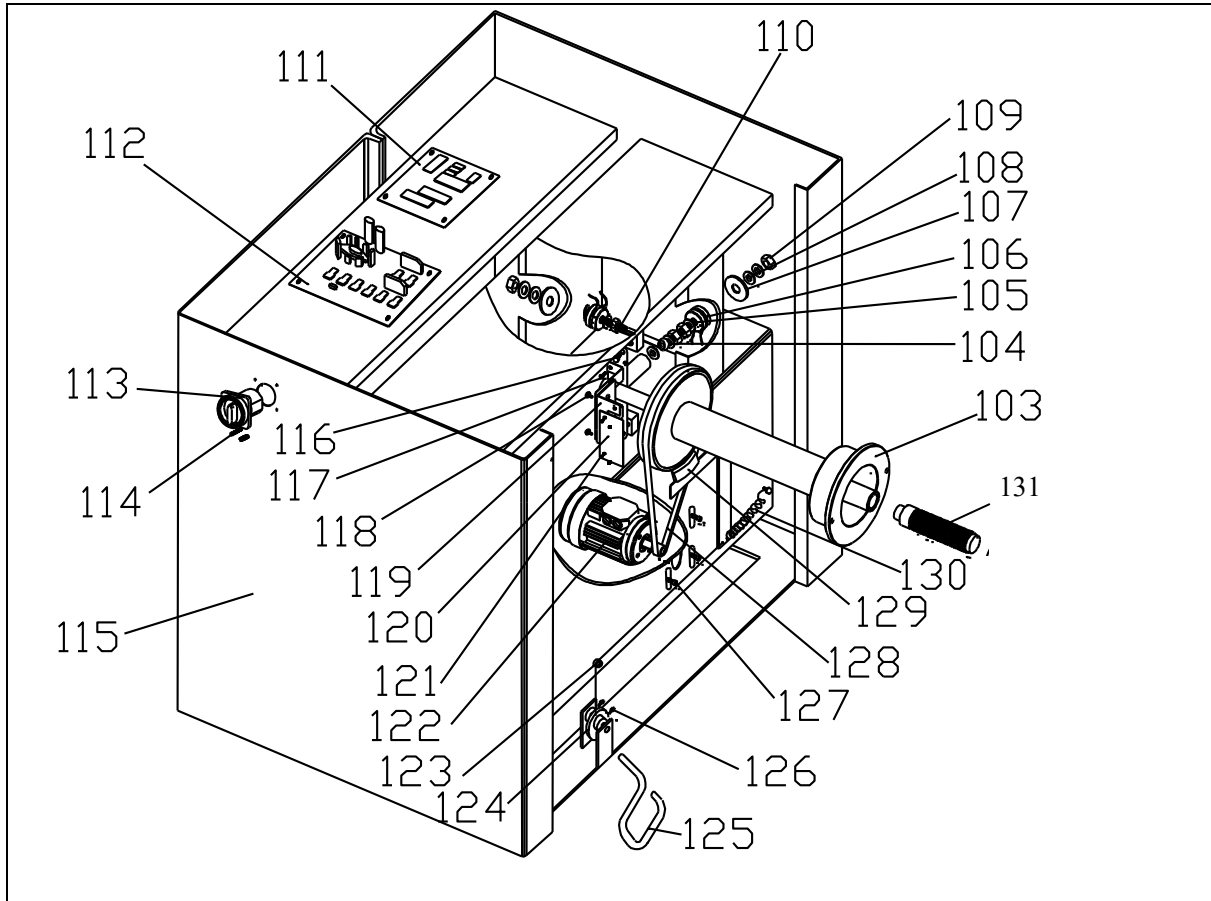

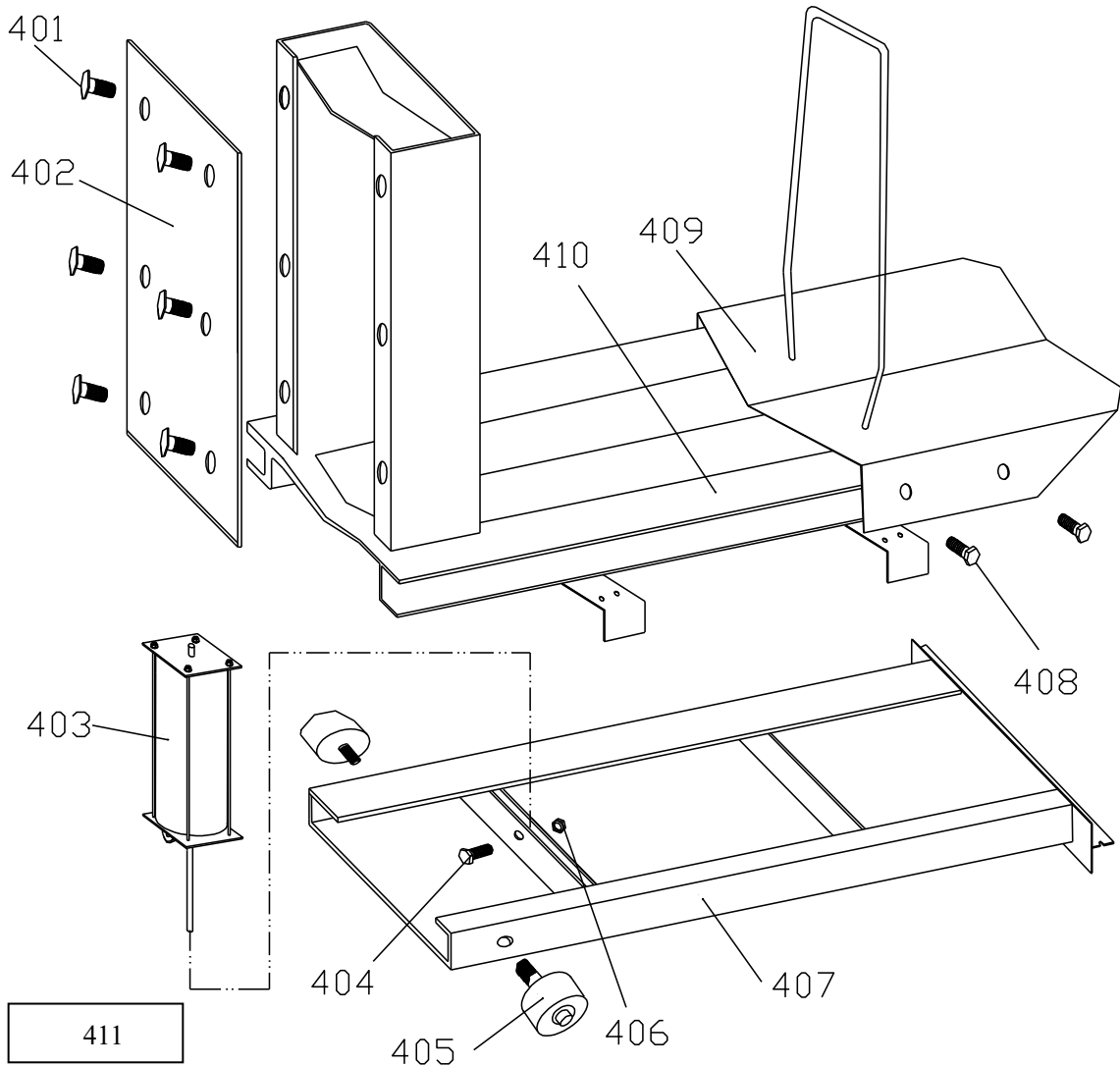
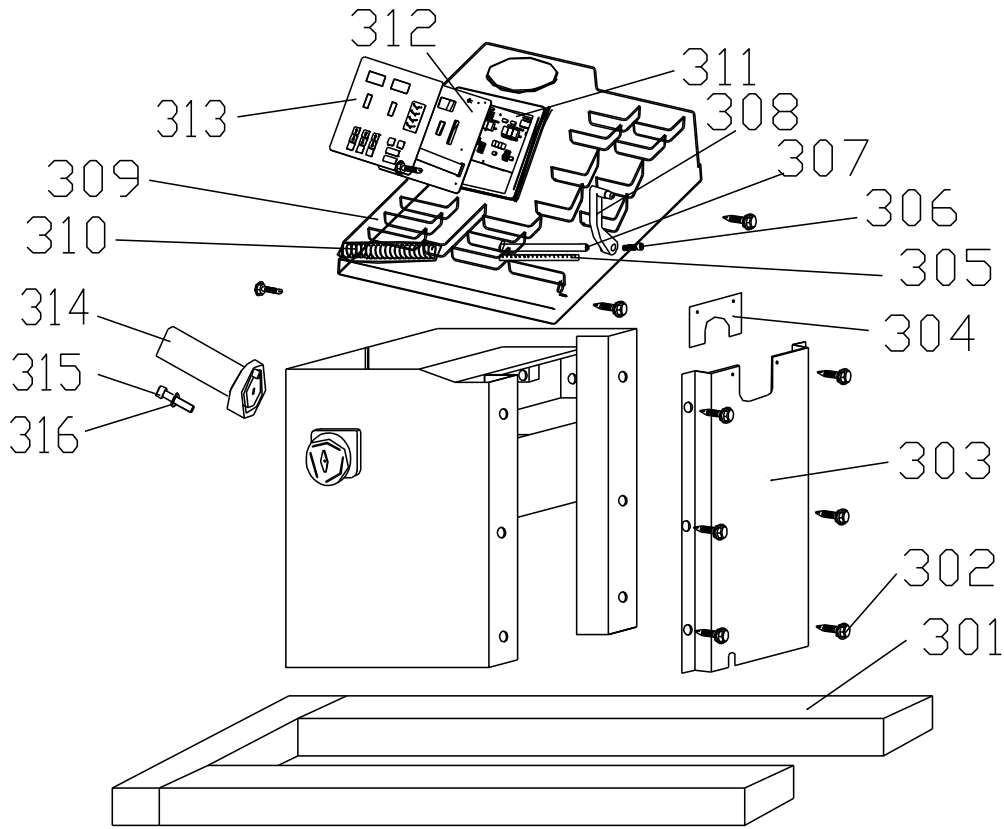

**17. Spare parts list**

<b>NO.</b>	<b>Description</b>	<b>NO.</b>	<b>Description</b>	<b>NO.</b>	<b>Description</b>
103	Complete Shaft X000423	123	Brake pulley X004562	301	Pedestal
104	Washer	124	Brake Rotate pulley X003989	302	Screw
105	Through bolt (H)	125	Brake pedal X000431	303	Big plate
106	Sensor assembly X000424	126	Screw	304	Small plate
107	Washer	127	Screw	305	Graduated strip Y-004-000070-0
108	Butterfly washer	128	Belt X001802	306	Screw
109	Nut	129	Brake patch	307	Rim scale P-500-090000-0
110	Thread Bolt X003347	130	Spring X004566	308	Handle bar P-100-160000-0
111	Computer board PZ-000-010950-0	131	Thread shaft X002790	309	Head with tools-tray P-850-190000-0
112	Power board 220v 1ph PZ-000-020950-1			310	Spring P-100-210000-0
112	Power board 3800v 3ph PZ-000-020950-N	201	Protection hood Cover	311	Display board PZ-000-010950-5
113	Switch X000429	202	Screw	312	Display fixed plate X002789
114	Screw	203	Screw	313	Key board S-115-008500-0
115	Body	204	Washer	314	Tools hang
116	Screw	205	Washer	315	Screw
117	Screw	206	Nut B-004-080001-0	316	Washer
118	Screw	207	Spring		
119	Support	208	Protection hood X000433	401	Screw
120	Position Pick-up Board X000430	209	Support	402	Cover board
121	Screw	210	Screw	403	Cylinder casing
122	MOTOR, for Truck Wheel balancer 380V W-070-000122-0	211	Nut	404	Screw
122	MOTOR for Truck Wheel balancer 220V W-001-000850-1			405	Pulley
				406	Nut
				407	Lift pedestal
				408	Screw
				409	Move board
				410	Lift desk
				411	Complete Lifting device assembly-truck balancer X000476

**Standard Spare parts**

X000415	X000416	X000417	X000418	X000419
Centring cone for truck 1#	Centring cone for truck 2#	Large cone 1# for truck	Large cone 2# for truck	Large spacing ring for large cone 1#&2#
X000420	X000421	X000414	X000412	X000413
Large cone 3# for truck	Large spacing ring for large cone 3#	Caliper	Locking Nut Handle	Locking Nut
Plier	X001963	X005563	X001965	X001966
S-108-000010-0	COUNTER WEIGHT 50G	COUNTER WEIGHT 100G	COUNTER WEIGHT 150G	COUNTER WEIGHT 200G
X001967	X001968	S-110-001000-7		
COUNTER WEIGHT 250G	COUNTER WEIGHT 300G	Standard Wetights 100g		

**Optional Spare parts**

X000451
Universal wheel flange for truck balancer